



# ABUCompact

---

Product information / Technical data

**MORRIS**  
AFRICA'S LIFTING LEGEND

**ABUS**  
CRANE SYSTEMS

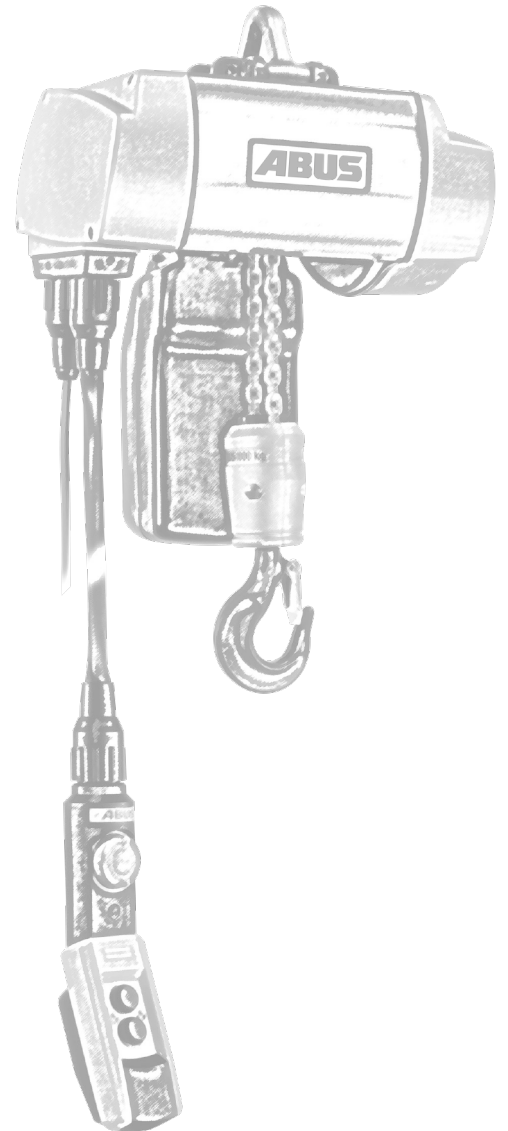
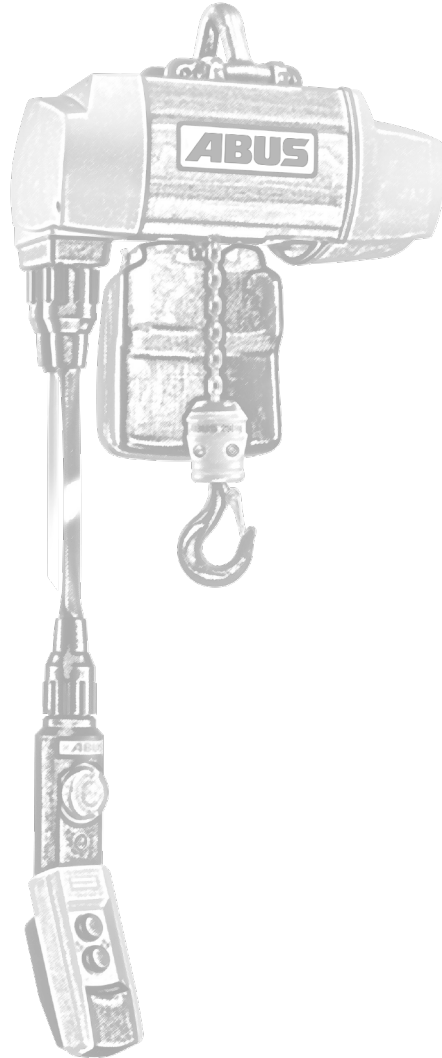
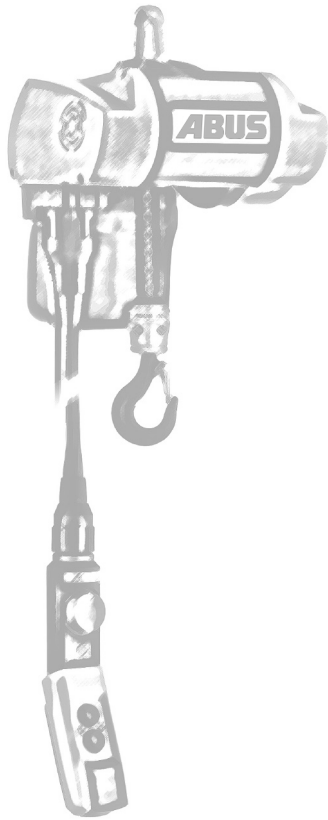

Dimensioned sketches  
ABUCompact GMC, GM2 and GM4

Please fold page out

# Dimensioned sketches of chain hoists

## ABUCompact GMC, GM2 and GM4

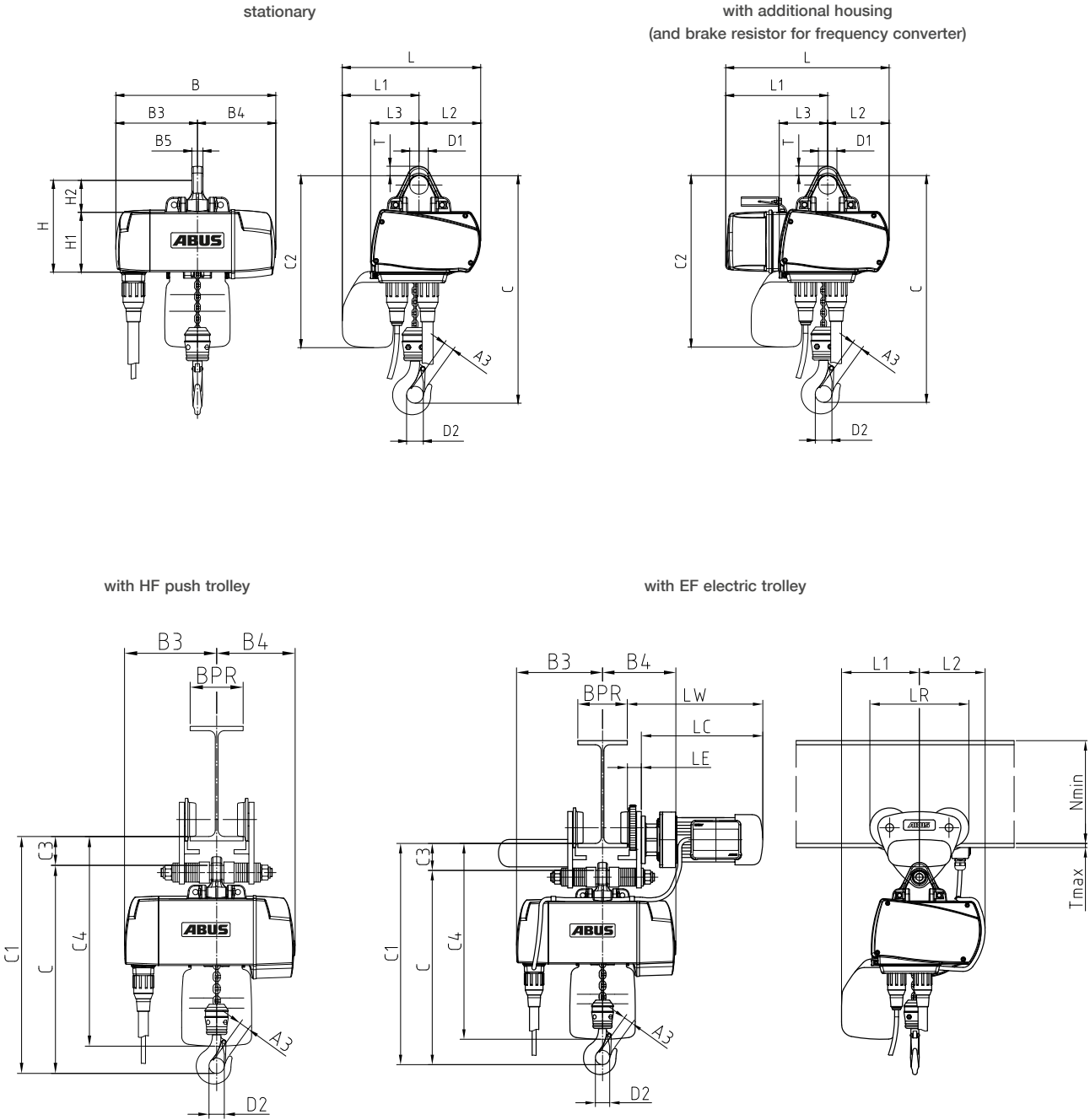

# Description

## of the standard equipment

The new generation of ABUCompact chain hoists feature a fresh new design and convincing technical solutions. The 3 phase 400 volt hoists units are available in four different sizes to reliably handle loads from 80 kg through 4000 kg.

The motor and the gear unit are of modular design, allowing us to produce a wide variety of versions for lifting speeds up to 20 m/min and FEM groups up to 4 m at attractive prices.

Details of the ABUS electric chain hoist range and introduction dates are given in the selection table. Why not take advantage of the additional features described from page 8 onwards.

The small GMC hoist rounds off the ABUCompact range. With infinitely variable lifting speed and a load capacity of 100 kg or 200 kg, this unit, supplied ready for connection to a 230 V power socket, is the ideal hoist for flexible and low capacity applications.



### ABUCompact GMC

Scope of supply: electric chain hoist with pendant control handset and cable, ready to connect up to start work with its chain collector, chain, approximately 3 meters of mains power cable and connection already fitted.

- hoist body finish painted RAL 5017 (traffic blue)
- hinged, removable suspension bracket
- operating voltage: single-phase AC, 230 V, 50 Hz
- degree of protection IP 21, insulation class F
- operation via pendant control handset complete with emergency stop button, degree of protection IP 65
- infinitely variable lifting speed
- electronic control
- overload protection by slipping clutch with fixed adjustment
- high-strength, galvanized round steel chain with chain container
- hook path 3000 mm
- pendant control cable to suit hoist hook path
- plug and play connections



### ABUCompact GM2 to GM8

Scope of supply: electric chain hoist with pendant control handset and cable, ready to connect up to start work with its chain collector, chain and mains connection already fitted.

- hoist body finish painted RAL 5017 (traffic blue)
- hinged, removable suspension bracket
- operating voltage: 3-phase AC, 380 to 415 V, 50 Hz
- degree of protection IP 55, insulation class F
- operation via pendant control handset complete with emergency stop button, degree of protection IP 65
- direct control for GM2 / GM4 / GM6
- 48 V contactor control with semiconductor technology for GM8
- quick plug-type connections with twist lock
- 2 lifting speeds (main and precision lift)
- overload protection with externally adjustable slipping clutch
- high-strength, galvanized profile steel chain with chain container
- hook path 3000 mm
- pendant control cable to suit hoist hook path

# Contents

---

## Where do I find?

Page 3	Dimensioned sketches, ABUCompact GMC, GM2 and GM4
Page 4	Description of the standard equipment
Page 5	Contents
Page 6 + 7	Technical details – useful information on the ABUCompact GM2 to GM8
Page 8 + 9	Optional extras - for MORE convenience ABUS trolleys
Page 10	Drive group (FEM group) selection
Page 11	Selection tables / Type designation
Page 12 - 14	ABUCompact GM2 to GM8 & GMC electric chain hoists
Page 15	Longer hook paths / control lines
Page 16 - 17	Optional extras
Page 18	ABUS clamping buffers ABUS trolley current collectors
Page 19	ABUS festoon power supply system
Page 20	ABUS power supply system with mobile control
Page 21	ABUS safety conductor system
Page 22 - 28	Weights and dimensions ABUCompact GM2 to GM8 electric chain hoists ABUCompact GMC electric chain hoists ABUS HF push trolleys ABUS EF electric trolleys Suspension hooks / safety load hooks for use with ABUS electric chain hoists
Page 29	Anti-collision protection for ABUS trolleys EF/HF
Page 30	Dimensioned sketches of chain hoists, ABUCompact GM6 and GM8

# Technical details

useful information on the ABUCompact GM2 to GM8



## Standards and safety regulations

All ABUS chain hoists are designed and manufactured in accordance with the applicable EU directives and harmonized standards.

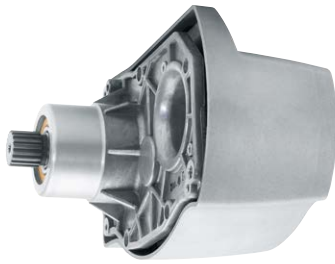

### Motor and gear unit

The motor and gear units are of modular design, allowing a variety of combinations for different lifting speeds. All the motors used are sturdy squirrel-cage units with 2-pole and 8-pole windings and the gear unit is separately encapsulated. This ensures considerable benefits for installation and maintenance. The permanently lubricated spur gear features bevelled gear wheels and roller bearings for smooth running.



### Integrated safety brake

The DC disk brake features asbestos-free brake linings with a long service life (a million braking operations up to the first adjustment). The adjustable brake is designed for a very short run-on.



### Suspension bracket

The removable, hinged suspension bracket is designed for easy suspension and removal of the hoist. The bracket ensures that the hoist is positioned in a fixed direction. On GM2 and GM4 hoists, the bracket is designed for installation in two positions, with an angle of 90° between them. Without the suspension bracket, the hoist may also be rigidly fixed by other means. The reduced installation spacing then allows an increase in the lifting height.

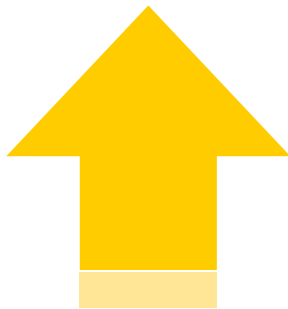

### 2 lifting speeds

Two lifting speeds, one for fast lifting and one for precision positioning, are a standard feature. The speed ratio (precision:main lift) is 1:4 for the GM2, GM4 and GM6 and 1:6 for the GM8.



### Chain system

The chain system consists of a high-precision chain sprocket entirely surrounded by the chain guide. Both the chain sprocket and the chain guide are of modular design, allowing easy replacement without the need to spend time and money dismantling the hoist to reach the parts.



### Slipping clutch

The slipping clutch offers reliable protection against overloading. Special linings designed for minimum wear ensure high safety levels over the entire service life of the unit. The slipping clutch is designed for easy external adjustment.



### Rotating hook block (single fall)

The hook block is designed to rotate on the chain. The hook and the hook block form a single, torsionally stable unit. The load can be effectively guided and oriented using a hand on the hook block.



### Quick plug-type connectors

The power supply and the control unit are connected up using quick plug-type connectors with twist locks. The connection is firm and confusion is not possible. These connectors save time and make installation and maintenance work safer.



### Sheathed control line

No external strainer cable is required as strain relief properties are built into the sheathing of the robust pendant cable. Tensile forces are absorbed by the specially coated fabric of the sheath. The conductors inside the sheath can move freely and are effectively protected against mechanical damage.



### Profile steel chain

The specially hardened galvanized steel profile chain allows loads about 25 % higher than a round steel chain of the same nominal dimensions. The larger area surface of the chain links has a positive effect on material wear properties. In practice, safety levels are improved and the service life of the chain is prolonged.

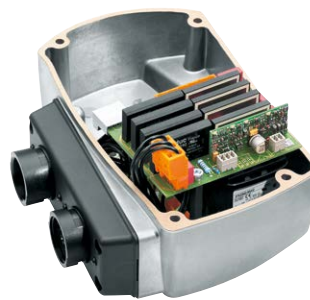

### 48 V semiconductor control

The electronic control features no-wear semiconductor technology. This configuration allows considerable weight and space savings compared with mechanical contactors. (Standard equipment for GM8, optional for GM2, GM4 and GM6).



### Operation via pendant control

ABUCompact hoists are controlled from ground level using ergonomically designed ABUCommander pendant controls with 2-stage push buttons and large emergency stop buttons. The pendant control is connected using quick plug-type connectors with twist locks (bayonet locks).

# Optional extras

for MORE convenience



## Operating hours meter

An operating hours meter allows a realistic assessment of the work actually performed by a hoist. The operating hours indicated can be used for calculating the remaining service life of the hoist in accordance with FEM 9.755. With an operating hours meter, longer safe working periods are normally possible.



## ABUliner frequency converter for lifting and lowering

Infinitely variable speed control for the smooth handling of sensitive products such as glass or ceramics or long, bulky loads. The ABUliner also allows precise positioning for tricky assembly and joining operations.

For additional safety, the frequency converter features an electronic shut-down system with two programmable shut-down points that can be set via the pendant control.



## Cruciform limit switch for trolley travel

These switches can be used to slow the trolley to a lower speed ahead of the end stops. When the trolley has passed the limit switch, it can be moved back in the other direction at low speed. This option is only available in combination with a contactor-type control system/semiconductor control system.

**Alternative:** Deceleration to low trolley travel speed **followed by shut-down** at the end of trolley travel before the end stops are reached. When the trolley has passed the limit switch, it can be moved back in the other direction at high speed.

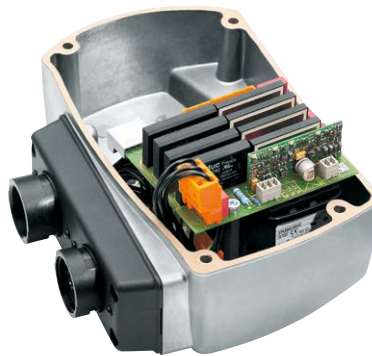

## 48 V semiconductor control for lifting and lowering

The electronical control system features advanced, no-wear semiconductor technology and is integrated in the hoist.

This configuration features considerable weight and space savings compared with conventional mechanical contactors. The control voltage is 48 V.

## Alternative: semiconductor control for lifting / lowering and trolley travel

Extended semiconductor electronic control system also incorporating trolley travel control functions. If this option is selected for a GM2 hoist, the control system is installed in an additional housing on the hoist.



## Electronic limit switch (two positions)

The electronic limit switch features two programmable shut-down points for even safer operation. The shut-down points for highest and lowest hook position can be programmed individually using a teach-in button on the pendant control. When the shut-down point is reached, the lifting or lowering movement is stopped. This option is only available in combination with a 48 V semiconductor control system.

## Alternative: limit switch with two additional switching points

This option features two additional switching points between the highest and lowest hook position. These can be used as stop-and-go points during operation.



### Additional power socket on hoist

This option includes an additional 5-pole (3/N/PE) power socket on the hoist for ancillary equipment. The socket is connected upstream from the emergency stop switch and the ancillary equipment therefore remains in operation following an emergency stop. Easy connection and disconnection is possible. Depending on the individual application, it may be necessary to provide a 5-pole power supply. (This option is only available in combination without electric trolley travel and with direct control)



Units for special voltages available on request:

440 – 480 V / 60 Hz  
208 – 230 V / 60 Hz  
220 – 240 V / 50 Hz  
550 – 600 V / 60 Hz  
360 – 400 V / 60 Hz  
460 – 500 V / 50 Hz

### Plug and play radio remote control unit Tiger G2

The radio remote control unit Tiger G2 has a range of up to 50 m. Scope of supply consists of a lightweight hand-held transmitter with a rechargeable battery, belt clip and receiver with integrated horn. The receiver is simply plugged in instead of the pendant control and is immediately ready for operation (plug-and-play). In order to control the lifting and lowering movement via radio, the chain hoist is equipped with a 48 V control system.

The radio remote control unit can be used with solo hoists (lifting/lowering) and trolleys (lifting/lowering and powered trolley travel). An electrical travel cruciform limit switch is required in the instance of powered trolley travel. For optimum operation, we strongly recommend that the travel motion is first slowed to its slow speed prior to complete stop, as this eradicates load swing.



## ABUS trolleys

### push trolleys & electric trolleys



#### ABUS HF push trolleys

- sturdy design with roller bearings
- virtually no maintenance required
- machined rollers
- fitted with drop stop and wheel climb prevention lugs
- colour RAL 5017 (traffic blue), suits many different chain hoist models
- adjustable for flange widths from 42 to 400 mm



#### ABUS EF electric trolleys

- sturdy design with roller bearings
- virtually no maintenance required
- speed 5/20 m/min or 7.5/30 m/min
- high-quality standard drive system
- degree of protection IP 55
- durable electromechanical disk brake
- machined rollers
- fitted with drop stop and wheel climb prevention lugs
- colour RAL 5017 (traffic blue), suits many different chain hoist models
- adjustable for flange widths from 64 to 400 mm

# Drive group (FEM group) selection

## An important subject

Apart from the type of hoist required, the load capacity, the hook path and the lifting speed, the drive or FEM group is one of the main criteria to consider when selecting a hoist. The drive group must be selected to ensure that the hoist is fit for use for its intended purpose. Standard hoists are normally designed for a mean theoretical service life of 10 years, subject to operation in accordance with FEM 9.511. If the drive group selected is not appropriate in view of actual service conditions, the actual service life may be considerably shorter than 10 years. The results are excessive expenditure for maintenance, repairs and overhauls. In Germany, accident prevention regulations VBG D8 and D6 require hoist operators to determine the used-up portion of the theoretical service life during each regular inspection of the hoist. When the theoretical service life has elapsed, the hoist must be decommissioned. Continued operation is only permitted if an inspector finds that there are no objections to continued operation and lays down conditions for operation. Normally, the inspector requires the hoist to be overhauled. The objective of these requirements is to ensure that each hoist is only operated within its safe working period (S.W.P.).

In addition to the mean working time per day,  $t_m$  (total average hours of operation of the hoist per day), the correct assessment of the load population is essential for selecting the appropriate drive group. The value  $t_m$  is given by the following equation:

$$t_m = \frac{2 \times \text{mean lifting height (m)} \times \text{load cycles (1/h)} \times \text{working time (h/day)}}{60 \text{ (min/h)} \times \text{lifting speed (m/min)}}$$

### Mean lifting height:

the average hook travel under actual operating conditions

### Load cycles:

the average number of lifting operations per hour. A load cycle consists of one lifting and one lowering operation, i.e. two hook movements (lifting operations with an empty hook as a result of process conditions must also be taken into account in determining load cycles, but also make the load population determined less severe.

### Working time:

average working time per day within which the average load cycles per hour are performed

### Lifting speed:

average lifting speed (normally the maximum lifting speed) at which the load cycles are performed.

The following table indicates the theoretical service life D in hours for FEM groups 1 Bm, 1 Am, 2 m, 3 m and 4 m.

	Drive group	1Bm/M3	1Am/M4	2m/M5	3m/M6	4m/M7
Line	Load population	Theoretical service life D (h)				
1	light	3200	6300	12500	25000	50000
2	medium	1600	3200	6300	12500	25000
3	heavy duty	800	1600	3200	6300	12500
4	very heavy duty	400	800	1600	3200	6300

The selection of the next highest FEM group results in a doubling of the theoretical service life if the operating conditions assumed remain unchanged.

Further information on this rather complex subject is given by FEM 9.755 and the fourth supplement to accident prevention regulation VBG 8 for winches, hoists and traction systems. We will also be pleased to send you our planning service form for selecting the correct FEM group as well as an article concerning the determination of remaining service life.

If the mean working time  $t_m$  and the load population are known, the correct drive group in accordance with DIN 15020 or FEM 9.755 can be selected using the following table.

Load population	Definition of load population	Mean working time $t_m$ per working day in h					
1 (light)	$(k \leq 0.50)$ Only operated at maximum load in exceptional cases, mainly operated at very low load, small dead load		$\leq 2$	2 – 4	4 – 8	8 – 16	$> 16$
2 (medium)	$(0.50 < k \leq 0.63)$ operated quite frequently at maximum load, operated continuously at low load, medium dead load		$\leq 1$	1 – 2	2 – 4	4 – 8	8 – 16
3 (heavy duty)	$(0.63 < k \leq 0.80)$ operated frequently at maximum load, operated continuously at medium load, heavy dead load		$\leq 0.5$	0.5 – 1	1 – 2	2 – 4	4 – 8
4 (very heavy duty)	$(0.80 < k \leq 1)$ operated regularly at maximum load, very heavy dead load		$\leq 0.25$	0.25 – 0.5	0.5 – 1	1 – 2	2 – 4
Drive/FEM group in accordance with DIN 15020 or FEM 9.511			1Bm	1Am	2m	3m	4m

# Selection tables

## Type designation

Electric chain hoists (operating voltage 400 V, 50 Hz, 3-phase)

Main lift	3 m/min	4 m/min	5 m/min	6 m/min		8 m/min		10 m/min		12 m/min	16 m/min	20 m/min
Load falls	2	2	2	1	2	1	2	1	2	1	1	1
Load capacity (kg)												
80				GM2 (4m)		GM2 (4m)		GM2 (4m)		GM2 (4m)	GM2 (4m)	GM2 (3m)
100				GM2 (4m)		GM2 (4m)		GM2 (4m)		GM2 (4m)	GM2 (3m)	GM2 (2m)
125				GM2 (4m)		GM2 (4m)		GM2 (4m)		GM2 (3m)	GM2 (2m)	
160	GM2 (4m)	GM2 (4m)	GM2 (4m)	GM2 (4m)	GM2 (4m)	GM2 (4m)	GM2 (4m)	GM2 (3m)	GM2 (3m)	GM2 (2m)		
200	GM2 (4m)	GM2 (4m)	GM2 (4m)	GM2 (3m)	GM2 (4m)	GM2 (3m)	GM2 (3m)	GM2 (2m)	GM2 (2m)			
250	GM2 (4m)	GM2 (4m)	GM2 (4m)	GM2 (2m)	GM2 (3m)	GM2 (2m)	GM2 (2m)	GM4 (4m)		GM4 (4m)	GM4 (3m)	GM4 (2m)
320	GM2 (4m)	GM2 (4m)	GM2 (3m)	GM2 (1Am)	GM2 (2m)	GM4 (4m)		GM4 (4m)		GM4 (3m)	GM4 (2m)	
400	GM2 (3m)	GM2 (3m)	GM2 (2m)			GM4 (3m)		GM4 (3m)		GM4 (2m)		
500	GM2 (2m)	GM2 (2m)	GM4 (4m)		GM4 (4m)	GM4 (2m)	GM4 (3m)	GM4 (2m)	GM4 (2m)			
630	GM2 (1Am)	GM4 (4m)	GM4 (4m)	GM6 (4m)	GM4 (3m)	GM4 (1Am)	GM4 (2m)	GM6 (4m)		GM6 (3m)	GM6 (3m)	
800		GM4 (3m)	GM4 (3m)	GM6 (3m)	GM4 (2m)	GM6 (3m)		GM6 (3m)		GM6 (2m)	GM8 (3m)	GM8 (2m)
1000		GM4 (2m)	GM4 (2m)	GM6 (2m)		GM6 (2m)		GM6 (2m)		GM8 (3m)	GM8 (2m)	
1250	GM6 (4m)	GM4 (1Am)	GM6 (4m)	GM6 (1Am)	GM6 (3m)	GM6 (1Am)	GM6 (3m)	GM8 (2m)		GM8 (2m)		
1600	GM6 (3m)	GM6 (3m)	GM6 (3m)		GM6 (2m)	GM8 (2m)	GM8 (3m)	GM8 (1Am)	GM8 (2m)			
2000	GM6 (2m)	GM6 (2m)	GM6 (2m)		GM8 (3m)	GM8 (1Am)	GM8 (2m)					
2500	GM6 (1Am)	GM6 (1Am)	GM8 (2m)		GM8 (2m)							
3200		GM8 (2m)	GM8 (1Am)									
4000		GM8 (1Am)										

Explanation of the type designation

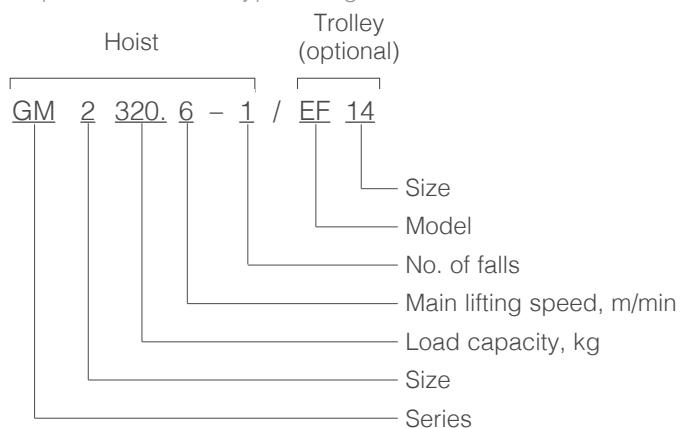

Electric chain hoists (operating voltage 230 V, 50 Hz, 1 phase)

Main lift	6 m/min (infinitely variable)	12 m/min (infinitely variable)
Load falls	2	1
Load capacity		
100 kg		GMC (1Am)
200 kg	GMC (1Am)	

# ABUCompact GM2 to GM8 electric chain hoists

operating voltage 400 V, 50 Hz, 3-phase

Load capacity	Lifting speed	FEM/ISO	Model	Load falls	Hook	Motor			With push trolley	With electric trolley
						kw	%ED <sup>1)</sup>	c/h		
kg	m/min							Model	Model	
80	1,5 / 6,0	4m / M7	GM 2 80.6-1	1	012	0,09 / 0,35	60	360	HF 3	EF 14
80	2,0 / 8,0	4m / M7	GM 2 80.8-1	1	012	0,09 / 0,35	60	360	HF 3	EF 14
80	2,5 / 10,0	4m / M7	GM 2 80.10-1	1	012	0,09 / 0,35	60	360	HF 3	EF 14
80	3,0 / 12,0	4m / M7	GM 2 80.12-1	1	012	0,09 / 0,35	60	360	HF 3	EF 14
80	4,0 / 16,0	4m / M7	GM 2 80.16-1	1	012	0,09 / 0,35	60	360	HF 3	EF 14
80	5,0 / 20,0	3m / M6	GM 2 80.20-1	1	012	0,09 / 0,35	60	360	HF 3	EF 14
100	1,5 / 6,0	4m / M7	GM 2 100.6-1	1	012	0,09 / 0,35	60	360	HF 3	EF 14
100	2,0 / 8,0	4m / M7	GM 2 100.8-1	1	012	0,09 / 0,35	60	360	HF 3	EF 14
100	2,5 / 10,0	4m / M7	GM 2 100.10-1	1	012	0,09 / 0,35	60	360	HF 3	EF 14
100	3,0 / 12,0	4m / M7	GM 2 100.12-1	1	012	0,09 / 0,35	60	360	HF 3	EF 14
100	4,0 / 16,0	3m / M6	GM 2 100.16-1	1	012	0,09 / 0,35	60	360	HF 3	EF 14
100	5,0 / 20,0	2m / M5	GM 2 100.20-1	1	012	0,09 / 0,35	60	360	HF 3	EF 14
125	1,5 / 6,0	4m / M7	GM 2 125.6-1	1	012	0,09 / 0,35	60	360	HF 3	EF 14
125	2,0 / 8,0	4m / M7	GM 2 125.8-1	1	012	0,09 / 0,35	60	360	HF 3	EF 14
125	2,5 / 10,0	4m / M7	GM 2 125.10-1	1	012	0,09 / 0,35	60	360	HF 3	EF 14
125	3,0 / 12,0	3m / M6	GM 2 125.12-1	1	012	0,09 / 0,35	60	360	HF 3	EF 14
125	4,0 / 16,0	2m / M5	GM 2 125.16-1	1	012	0,09 / 0,35	60	360	HF 3	EF 14
160	0,8 / 3,0	4m / M7	GM 2 160.3-2	2	05	0,09 / 0,35	60	360	HF 3	EF 14
160	1,0 / 4,0	4m / M7	GM 2 160.4-2	2	05	0,09 / 0,35	60	360	HF 3	EF 14
160	1,3 / 5,0	4m / M7	GM 2 160.5-2	2	05	0,09 / 0,35	60	360	HF 3	EF 14
160	1,5 / 6,0	4m / M7	GM 2 160.6-2	2	05	0,09 / 0,35	60	360	HF 3	EF 14
160	1,5 / 6,0	4m / M7	GM 2 160.6-1	1	012	0,09 / 0,35	60	360	HF 3	EF 14
160	2,0 / 8,0	4m / M7	GM 2 160.8-2	2	05	0,09 / 0,35	60	360	HF 3	EF 14
160	2,0 / 8,0	4m / M7	GM 2 160.8-1	1	012	0,09 / 0,35	60	360	HF 3	EF 14
160	2,5 / 10,0	3m / M6	GM 2 160.10-2	2	05	0,09 / 0,35	60	360	HF 3	EF 14
160	2,5 / 10,0	3m / M6	GM 2 160.10-1	1	012	0,09 / 0,35	60	360	HF 3	EF 14
160	3,0 / 12,0	2m / M5	GM 2 160.12-1	1	012	0,09 / 0,35	60	360	HF 3	EF 14
200	0,8 / 3,0	4m / M7	GM 2 200.3-2	2	05	0,09 / 0,35	60	360	HF 3	EF 14
200	1,0 / 4,0	4m / M7	GM 2 200.4-2	2	05	0,09 / 0,35	60	360	HF 3	EF 14
200	1,3 / 5,0	4m / M7	GM 2 200.5-2	2	05	0,09 / 0,35	60	360	HF 3	EF 14
200	1,5 / 6,0	4m / M7	GM 2 200.6-2	2	05	0,09 / 0,35	60	360	HF 3	EF 14
200	1,5 / 6,0	3m / M6	GM 2 200.6-1	1	012	0,09 / 0,35	60	360	HF 3	EF 14
200	2,0 / 8,0	3m / M6	GM 2 200.8-2	2	05	0,09 / 0,35	60	360	HF 3	EF 14
200	2,0 / 8,0	3m / M6	GM 2 200.8-1	1	012	0,09 / 0,35	60	360	HF 3	EF 14
200	2,5 / 10,0	2m / M5	GM 2 200.10-2	2	05	0,09 / 0,35	60	360	HF 3	EF 14
200	2,5 / 10,0	2m / M5	GM 2 200.10-1	1	012	0,09 / 0,35	60	360	HF 3	EF 14
250	0,8 / 3,0	4m / M7	GM 2 250.3-2	2	05	0,09 / 0,35	60	360	HF 3	EF 14
250	1,0 / 4,0	4m / M7	GM 2 250.4-2	2	05	0,09 / 0,35	60	360	HF 3	EF 14
250	1,3 / 5,0	4m / M7	GM 2 250.5-2	2	05	0,09 / 0,35	60	360	HF 3	EF 14
250	1,5 / 6,0	3m / M6	GM 2 250.6-2	2	05	0,09 / 0,35	60	360	HF 3	EF 14
250	1,5 / 6,0	2m / M5	GM 2 250.6-1	1	012	0,09 / 0,35	60	360	HF 3	EF 14
250	2,0 / 8,0	2m / M5	GM 2 250.8-1	1	012	0,09 / 0,35	60	360	HF 3	EF 14
250	2,0 / 8,0	2m / M5	GM 2 250.8-2	2	05	0,09 / 0,35	60	360	HF 3	EF 14
250	2,0 / 8,0	4m / M7	GM 4 250.8-1	1	025	0,22 / 0,9	60	360	HF 3	EF 14
250	2,5 / 10,0	4m / M7	GM 4 250.10-1	1	025	0,22 / 0,9	60	360	HF 3	EF 14
250	3,0 / 12,0	4m / M7	GM 4 250.12-1	1	025	0,22 / 0,9	60	360	HF 3	EF 14
250	4,0 / 16,0	3m / M6	GM 4 250.16-1	1	025	0,22 / 0,9	60	360	HF 3	EF 14
250	5,0 / 20,0	2m / M5	GM 4 250.20-1	1	025	0,22 / 0,9	60	360	HF 3	EF 14
320	0,8 / 3,0	4m / M7	GM 2 320.3-2	2	05	0,09 / 0,35	60	360	HF 6	EF 14
320	1,0 / 4,0	4m / M7	GM 2 320.4-2	2	05	0,09 / 0,35	60	360	HF 6	EF 14
320	1,3 / 5,0	3m / M6	GM 2 320.5-2	2	05	0,09 / 0,35	60	360	HF 6	EF 14
320	1,5 / 6,0	1Am / M4	GM 2 320.6-1	1	025	0,09 / 0,35	60	360	HF 6	EF 14
320	1,5 / 6,0	2m / M5	GM 2 320.6-2	2	05	0,09 / 0,35	60	360	HF 6	EF 14
320	2,0 / 8,0	4m / M7	GM 4 320.8-1	1	025	0,22 / 0,9	60	360	HF 6	EF 14
320	2,5 / 10,0	4m / M7	GM 4 320.10-1	1	025	0,22 / 0,9	60	360	HF 6	EF 14
320	3,0 / 12,0	3m / M6	GM 4 320.12-1	1	025	0,22 / 0,9	60	360	HF 6	EF 14
320	4,0 / 16,0	2m / M5	GM 4 320.16-1	1	025	0,22 / 0,9	60	360	HF 6	EF 14

<sup>1)</sup>Duty cycle, %

Load capacity	Lifting speed	FEM/ISO	Model	Load falls	Hook	Motor			With push trolley	With electric trolley
						kw	%ED <sup>1)</sup>	c/h		
kg	m/min								Model	Model
400	0,8 / 3,0	3m / M6	GM 2 400.3-2	2	05	0,09 / 0,35	60	360	HF 6	EF 14
400	1,0 / 4,0	3m / M6	GM 2 400.4-2	2	05	0,09 / 0,35	60	360	HF 6	EF 14
400	1,3 / 5,0	2m / M5	GM 2 400.5-2	2	05	0,09 / 0,35	60	360	HF 6	EF 14
400	2,0 / 8,0	3m / M6	GM 4 400.8-1	1	025	0,22 / 0,9	60	360	HF 6	EF 14
400	2,5 / 10,0	3m / M6	GM 4 400.10-1	1	025	0,22 / 0,9	60	360	HF 6	EF 14
400	3,0 / 12,0	2m / M5	GM 4 400.12-1	1	025	0,22 / 0,9	60	360	HF 6	EF 14
500	0,8 / 3,0	2m / M5	GM 2 500.3-2	2	05	0,09 / 0,35	60	360	HF 6	EF 14
500	1,0 / 4,0	2m / M5	GM 2 500.4-2	2	05	0,09 / 0,35	60	360	HF 6	EF 14
500	1,0 / 4,0	4m / M7	GM 4 500.4-2	2	05	0,22 / 0,9	60	360	HF 6	EF 14
500	1,3 / 5,0	4m / M7	GM 4 500.5-2	2	05	0,22 / 0,9	60	360	HF 6	EF 14
500	1,5 / 6,0	4m / M7	GM 4 500.6-2	2	05	0,22 / 0,9	60	360	HF 6	EF 14
500	2,0 / 8,0	3m / M6	GM 4 500.8-2	2	05	0,22 / 0,9	60	360	HF 6	EF 14
500	2,0 / 8,0	2m / M5	GM 4 500.8-1	1	025	0,22 / 0,9	60	360	HF 6	EF 14
500	2,5 / 10,0	2m / M5	GM 4 500.10-2	2	05	0,22 / 0,9	60	360	HF 6	EF 14
500	2,5 / 10,0	2m / M5	GM 4 500.10-1	1	025	0,22 / 0,9	60	360	HF 6	EF 14
630	0,8 / 3,0	1Am / M4	GM 2 630.3-2	2	05	0,09 / 0,35	60	360	HF 14	EF 14
630	1,0 / 4,0	4m / M7	GM 4 630.4-2	2	05	0,22 / 0,9	60	360	HF 14	EF 14
630	1,3 / 5,0	4m / M7	GM 4 630.5-2	2	05	0,22 / 0,9	60	360	HF 14	EF 14
630	1,5 / 6,0	3m / M6	GM 4 630.6-2	2	05	0,22 / 0,9	60	360	HF 14	EF 14
630	2,0 / 8,0	1Am / M4	GM 4 630.8-1	1	025	0,22 / 0,9	60	360	HF 14	EF 14
630	2,0 / 8,0	2m / M5	GM 4 630.8-2	2	05	0,22 / 0,9	60	360	HF 14	EF 14
630	1,5 / 6,0	4m / M7	GM 6 630.6-1	1	05	0,4 / 1,7	50	300	HF 14	EF 14
630	2,0 / 8,0	4m / M7	GM 6 630.8-1	1	05	0,4 / 1,7	50	300	HF 14	EF 14
630	2,5 / 10,0	4m / M7	GM 6 630.10-1	1	05	0,4 / 1,7	50	300	HF 14	EF 14
630	3,0 / 12,0	3m / M6	GM 6 630.12-1	1	05	0,4 / 1,7	50	300	HF 14	EF 14
630	4,0 / 16,0	3m / M6	GM 6 630.16-1	1	05	0,4 / 1,7	50	300	HF 14	EF 14
800	1,0 / 4,0	3m / M6	GM 4 800.4-2	2	05	0,22 / 0,9	60	360	HF 14	EF 14
800	1,3 / 5,0	3m / M6	GM 4 800.5-2	2	05	0,22 / 0,9	60	360	HF 14	EF 14
800	1,5 / 6,0	2m / M5	GM 4 800.6-2	2	05	0,22 / 0,9	60	360	HF 14	EF 14
800	1,5 / 6,0	3m / M6	GM 6 800.6-1	1	05	0,4 / 1,7	50	300	HF 14	EF 14
800	2,0 / 8,0	3m / M6	GM 6 800.8-1	1	05	0,4 / 1,7	50	300	HF 14	EF 14
800	2,5 / 10,0	3m / M6	GM 6 800.10-1	1	05	0,4 / 1,7	50	300	HF 14	EF 14
800	3,0 / 12,0	2m / M5	GM 6 800.12-1	1	05	0,4 / 1,7	50	300	HF 14	EF 14
800	1,3 / 8,0	3m / M6	GM 8 800.8-1	1	05	0,2 / 1,3	50	300	HF 22	EF 22
800	1,7 / 10,0	3m / M6	GM 8 800.10-1	1	05	0,3 / 1,6	50	300	HF 22	EF 22
800	2,0 / 12,0	3m / M6	GM 8 800.12-1	1	05	0,33 / 2	50	300	HF 22	EF 22
800	2,7 / 16,0	3m / M6	GM 8 800.16-1	1	05	0,4 / 2,5	50	300	HF 22	EF 22
800	3,3 / 20,0	2m / M5	GM 8 800.20-1	1	05	0,5 / 3	40	240	HF 22	EF 22
1000	1,0 / 4,0	2m / M5	GM 4 1000.4-2	2	05	0,22 / 0,9	60	360	HF 14	EF 14
1000	1,3 / 5,0	2m / M5	GM 4 1000.5-2	2	05	0,22 / 0,9	60	360	HF 14	EF 14
1000	1,5 / 6,0	2m / M5	GM 6 1000.6-1	1	05	0,4 / 1,7	50	300	HF 14	EF 14
1000	2,0 / 8,0	2m / M5	GM 6 1000.8-1	1	05	0,4 / 1,7	50	300	HF 14	EF 14
1000	2,5 / 10,0	2m / M5	GM 6 1000.10-1	1	05	0,4 / 1,7	50	300	HF 14	EF 14
1000	1,3 / 8,0	3m / M6	GM 8 1000.8-1	1	05	0,3 / 1,6	50	300	HF 22	EF 22
1000	1,7 / 10,0	3m / M6	GM 8 1000.10-1	1	05	0,33 / 2	50	300	HF 22	EF 22
1000	2,0 / 12,0	3m / M6	GM 8 1000.12-1	1	05	0,4 / 2,5	50	300	HF 22	EF 22
1000	2,7 / 16,0	2m / M5	GM 8 1000.16-1	1	05	0,5 / 3	40	240	HF 22	EF 22
1250	1,0 / 4,0	1Am / M4	GM 4 1250.4-2	2	05	0,22 / 0,9	60	360	HF 14	EF 14
1250	0,8 / 3,0	4m / M7	GM 6 1250.3-2	2	1.0	0,4 / 1,7	50	300	HF 14	EF 14
1250	1,0 / 4,0	4m / M7	GM 6 1250.4-2	2	1.0	0,4 / 1,7	50	300	HF 14	EF 14
1250	1,3 / 5,0	4m / M7	GM 6 1250.5-2	2	1.0	0,4 / 1,7	50	300	HF 14	EF 14
1250	1,5 / 6,0	3m / M6	GM 6 1250.6-2	2	1.0	0,4 / 1,7	50	300	HF 14	EF 14
1250	1,5 / 6,0	1Am / M4	GM 6 1250.6-1	1	05	0,4 / 1,7	50	300	HF 14	EF 14
1250	2,0 / 8,0	3m / M6	GM 6 1250.8-2	2	1.0	0,4 / 1,7	50	300	HF 14	EF 14
1250	2,0 / 8,0	1Am / M4	GM 6 1250.8-1	1	05	0,4 / 1,7	50	300	HF 14	EF 14
1250	1,3 / 8,0	3m / M6	GM 8 1250.8-1	1	05	0,33 / 2	50	300	HF 22	EF 22
1250	1,7 / 10,0	2m / M5	GM 8 1250.10-1	1	05	0,4 / 2,5	40	240	HF 22	EF 22
1250	2,0 / 12,0	2m / M5	GM 8 1250.12-1	1	05	0,5 / 3	40	240	HF 22	EF 22

# ABUCompact GM2 to GM8 electric chain hoists

operating voltage 400 V, 50 Hz, 3-phase

Load capacity kg	Lifting speed m/min	FEM/ISO	Model	Load falls	Hook	Motor			With push trolley	With electric trolley
						kw	%ED <sup>1)</sup>	c/h	Model	Model
1600	0,8 / 3,0	3m / M6	GM 6 1600.3-2	2	1.0	0,4 / 1,7	50	300	HF 22	EF 22
1600	1,0 / 4,0	3m / M6	GM 6 1600.4-2	2	1.0	0,4 / 1,7	50	300	HF 22	EF 22
1600	1,3 / 5,0	3m / M6	GM 6 1600.5-2	2	1.0	0,4 / 1,7	50	300	HF 22	EF 22
1600	1,5 / 6,0	2m / M5	GM 6 1600.6-2	2	1.0	0,4 / 1,7	50	300	HF 22	EF 22
1600	0,7 / 4,0	3m / M6	GM 8 1600.4-2	2	1.0	0,2 / 1,3	50	300	HF 22	EF 22
1600	0,8 / 5,0	3m / M6	GM 8 1600.5-2	2	1.0	0,3 / 1,6	50	300	HF 22	EF 22
1600	1,0 / 6,0	3m / M6	GM 8 1600.6-2	2	1.0	0,33 / 2	50	300	HF 22	EF 22
1600	1,3 / 8,0	3m / M6	GM 8 1600.8-2	2	1.0	0,4 / 2,5	50	300	HF 22	EF 22
1600	1,3 / 8,0	2m / M5	GM 8 1600.8-1	1	05	0,4 / 2,5	40	240	HF 22	EF 22
1600	1,7 / 10,0	1Am / M4	GM 8 1600.10-1	1	05	0,5 / 3	40	240	HF 22	EF 22
1600	1,7 / 10,0	2m / M5	GM 8 1600.10-2	2	1.0	0,5 / 3	40	240	HF 22	EF 22
2000	0,8 / 3,0	2m / M5	GM 6 2000.3-2	2	1.0	0,4 / 1,7	50	300	HF 22	EF 22
2000	1,0 / 4,0	2m / M5	GM 6 2000.4-2	2	1.0	0,4 / 1,7	50	300	HF 22	EF 22
2000	1,3 / 5,0	2m / M5	GM 6 2000.5-2	2	1.0	0,4 / 1,7	50	300	HF 22	EF 22
2000	0,7 / 4,0	3m / M6	GM 8 2000.4-2	2	1.0	0,3 / 1,6	50	300	HF 22	EF 22
2000	0,8 / 5,0	3m / M6	GM 8 2000.5-2	2	1.0	0,33 / 2	50	300	HF 22	EF 22
2000	1,0 / 6,0	3m / M6	GM 8 2000.6-2	2	1.0	0,4 / 2,5	50	300	HF 22	EF 22
2000	1,3 / 8,0	2m / M5	GM 8 2000.8-2	2	1.0	0,5 / 3	40	240	HF 22	EF 22
2000	1,3 / 8,0	1Am / M4	GM 8 2000.8-1	1	05	0,5 / 3	40	240	HF 22	EF 22
2500	0,8 / 3,0	1Am / M4	GM 6 2500.3-2	2	1.0	0,4 / 1,7	50	300	HF 36	EF 36
2500	1,0 / 4,0	1Am / M4	GM 6 2500.4-2	2	1.0	0,4 / 1,7	50	300	HF 36	EF 36
2500	0,7 / 4,0	3m / M6	GM 8 2500.4-2	2	1.0	0,33 / 2	50	300	HF 36	EF 36
2500	0,8 / 5,0	2m / M5	GM 8 2500.5-2	2	1.0	0,4 / 2,5	40	240	HF 36	EF 36
2500	1,0 / 6,0	2m / M5	GM 8 2500.6-2	2	1.0	0,5 / 3	40	240	HF 36	EF 36
3200	0,7 / 4,0	2m / M5	GM 8 3200.4-2	2	1.0	0,4 / 2,5	40	240	HF 36	EF 36
3200	0,8 / 5,0	1Am / M4	GM 8 3200.5-2	2	1.0	0,5 / 3	40	240	HF 36	EF 36
4000	0,7 / 4,0	1Am / M4	GM 8 4000.4-2	2	1.0	0,5 / 3	40	240	HF 50	EF 50

# ABUCompact GMC electric chain hoists

operating voltage 230 V, 50 Hz, 1-phase

Load capacity kg	Lifting speed m/min	FEM/ISO	Model	Load falls	Hook path m	Hook	Motor			With push trolley
							kw	%ED <sup>1)</sup>	c/h	Model
100	0,7 - 12	1 Am / M4	GMC 100. 12-1	1	3 6 10 20	012	0,425	50	240	HF 3
200	0,3 - 6	1 Am / M4	GMC 200. 6-2	2	3 6 10	025	0,425	50	240	HF 3

<sup>1)</sup>Duty cycle, %

## Longer hook paths / control cables

Model	Load falls	Hook path mm	Chain container size
 GM2	1	3000 - 4000	1
		5000 - 10000	3
		11000 - 24000	4
		25000 - 32000	6
	2	3000 - 5000	3
		6000 - 12000	4
13000 - 16000	6		
 GM4	1	3000 - 4000	3
		5000 - 10000	4
		11000 - 24000	6
		25000 - 50000	7
	2	3000 - 5000	4
		6000 - 12000	6
13000 - 25000	7		
 GM6	1	3000 - 8000	5
		9000 - 20000	6
		21000 - 35000	7
	2	3000 - 4000	5
		5000 - 10000	6
		11000 - 17500	7
 GM8	1	3000 - 6000	7
		7000 - 16000	8
		17000 - 25000	8-600
		26000 - 32000	8-800
	2	3000	7
		4000 - 8000	8
		9000 - 12000	8-600
13000 - 16000	8-800		

# Optional extras

## Based on standard hoists:

stationary type, pendant control for lifting/lowering, control from trolley,

operating voltage 3~380-415 V / 50 Hz

GM2, GM4, GM6: direct control

GM8: 48 V semiconductor control

Possible scope of supply:

X Can be supplied as additional equipment, additional charge applies

(Z) Chain hoist with additional housing for extended electric/electronic equipment; For version with frequency converter supplemented by brake resistor; please note larger installation dimensions!

– not available

Options (Equipment package)	Electric movements H/S Lifting/lowering H/S/KF Lifting/lowering/ trolley travelling	Possible scope of supply				Notes on scope of supply
		GM2	GM4	GM6	GM8	
Additional connector plug for auxiliary equipment, 3 ph / N / PE	H/S	X	X	X	–	5-pole power supply and direct control required
Connector plug BJS24 for control cable on site	H/S/KF	X	X	X	X	
Electric trolley travelling control extension	H/S/KF	X	X	X	X	Pendant control with additional buttons, trolley motor cable, electrical system, GM8 with 48 V semiconductor control
Semiconductor control (HAC)	H/S	X	X	X	Standard	48 V control voltage
	H/S/KF	X (Z)	X	X	Standard	
Hoist limit switch						
electronic	H/S	X	X	X	X	Pendant control with teach-in button. Alternative: teach-in connector, incl. 48 V semiconductor control
		H/S/KF	X (Z)	X (Z)	X	
electromechanic						
2 shut-down points	H/S	–	X	X	X	Version for external control; supply without control cable and without push button pendant
	H/S/KF	–	X	X	X	
4 shut-down points	H/S	–	X	X	X	
	H/S/KF	–	X	X	X	
ABUliner frequency converter	H/S	X (Z)	X (Z)	X (Z)	X (Z)	Infinitely variable lifting speed, incl. electronic hoist limit switch and hours in service counter
	H/S/KF	on request	on request	on request	on request	
Radio remote control						
Type Tiger G2 Range: up to approx. 50 m	H/S	X	X	X	X	incl. 48 V semiconductor control and alarm horn, push button pendant as a back-up controller
	H/S/KF	X (Z)	X	X	X	Infinitely variable lifting speed, trolley travel limit switch and alarm horn; push button pendant as a back-up controller
Special voltages	H/S H/S/KF	X	X	X	X	Additional equipment for special voltages only on request



Options (individual)	Electric movements H/S Lifting/lowering H/S/KF Lifting/lowering/ trolley travelling	Possible scope of supply				Requirements
		GM2	GM4	GM6	GM8	
Operating hours meter	H/S H/S/KF	X	X	X	X	Only for an operating voltage of 380 - 415 V / 50 Hz; for GM2 housing extension necessary

Possible scope of supply:

X Can be supplied as additional equipment, additional charge applies

(Z) Chain hoist with additional housing for extended electric/electronic equipment; For version with frequency converter supplemented by brake resistor; please note larger installation dimensions!

– not available

Control via operational element on hook (larger C dimensions)

Hook path 3000 mm	H/S	X	X	–	–	GM2 with direct control or 48 V semiconductor control; GM4 only with 48 V semiconductor control; Load hook not rotating; Chain hoist single fall max. load capacity 250 kg
Hook path 4000 mm	H/S	X	X	–	–	
Hook path 5000 mm	H/S	X	X	–	–	
Hook 250 kg, rotatable	Order N° 103427	X	X	X	X	To complement the operational element
Coupling pin 250 kg	Order N° 82276	X	X	X	X	

Safety hook (larger C dimensions)

Single fall	H/S H/S/KF	X	X	X	X	
Double fall	H/S H/S/KF	X	X	–	–	

Retrofitting radio remote control

Chain hoist with 48 V semiconductor or contactor control

Type Tiger G2 Range: up to approx. 50 m	H/S	X	X	X	X	
	H/S/KF	X (Z)	X	X	X	Trolley travel limit switch required
Trolley travel limit switch	H/S/KF	X	X	X	X	Chain hoist with 48 V semiconductor/ contactor control

Spring reel for use at different operating levels

Extension length 3000 mm Load capacity 6 kg	H/S H/S/KF	X	X	X	X	Fitted directly to the chain hoist
Extension length 4500 mm Load capacity 8 kg	H/S H/S/KF	X	X	X	X	

Reduced equipment						Notes on scope of supply always including main connection plug
No pendant control, no control cable	H/S H/S/KF	X	X	X	X	including connector for control cable
		X	X	X	X	without connector for control cable
External control	H/S H/S/KF	X	X	X	X	Version for external control; delivery without control cable, without push button pendant
Suspension hooks		GMC	GM2	GM4	GM6	
		X	X	X	X	

# ABUS clamping buffers



Selection table for shaped clamping buffers

Type Size	Dimensions, mm							Weight kg
					Rubber			
	b	c	d	a	e	g	k	
alpha	110	20	63	45	40	15	26	2.6
beta	170	32	90	80	60	35	30	5.9

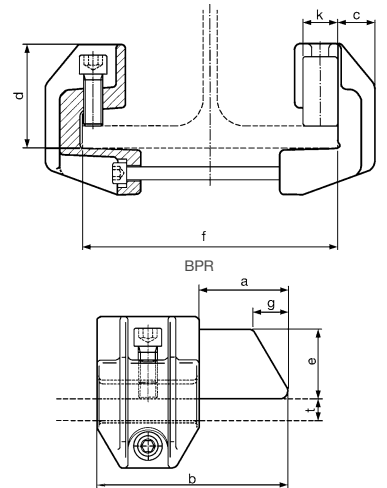

Type designations	Beam		For use with ABUS electric chain hoists	Ref.
	Flange width range mm	Flange thickness mm		
alpha	64 – 120	5.7 - 20.5	≤ 2.5 to	37329
	121 – 190			37434
	191 – 243			37435
	244 – 300			37443
beta	110 – 160	11.5 - 30	≤ 4 to	37444
	161 – 230			37445
	231 – 283			37446
	284 – 340			37447
	341 – 405			37448

Can be used with S 235 parallel flanged beams (free from oil and grease) and for trolleys with a max. travel speed of 36 m/min.

**Note:** For buffering a trolley on both sides, 2 clamping buffers are required.

# ABUS trolley current collectors

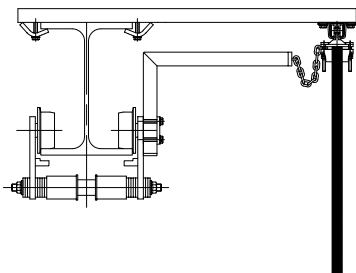

	Weight	Order N°
For the festoon power supply system	3.7 kg	309728
For the power conductor type KBH	2.4 kg	309729

# ABUS festoon power supply system

for track lengths up to 30 m

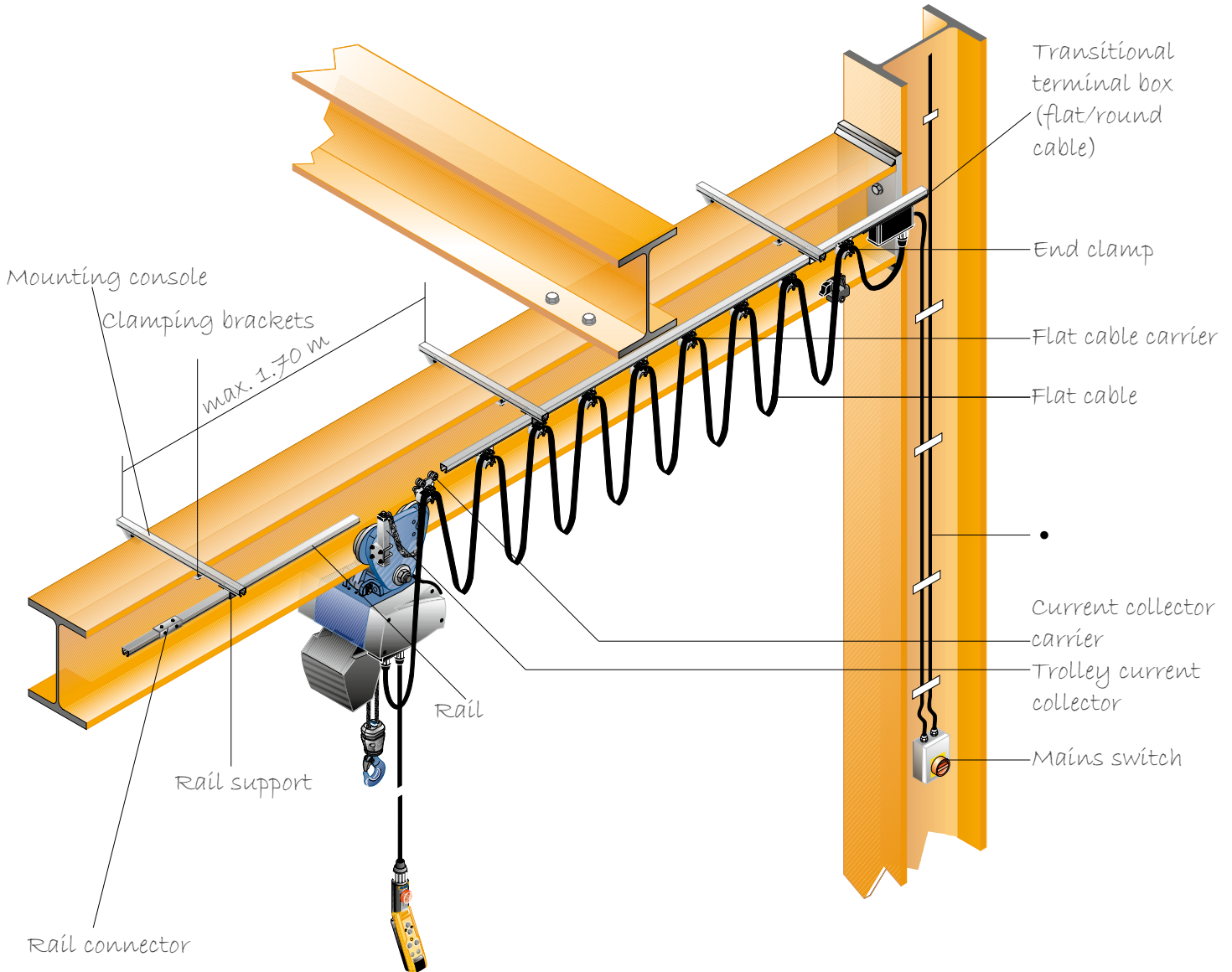

- The riser cable from the mains switch and cabling from the mains switch to the terminal box, including accessories, are not included in the scope of supply.

## Fixed components

Transitional terminal box, end clamp, current collector carrier, mains switch, trolley current collector

## Length-dependent components

Flat cable carriers, flat cable, rails, rail supports, rail connectors, mounting consoles, clamping brackets

The voltage drop must be taken into consideration for the design of the festoon system. The festoon system is prefabricated, i.e. supplied with the flat cable on the cable carriers, current collector carrier and end clamp.

# ABUS power supply system with mobile control

for track lengths up to 30 m

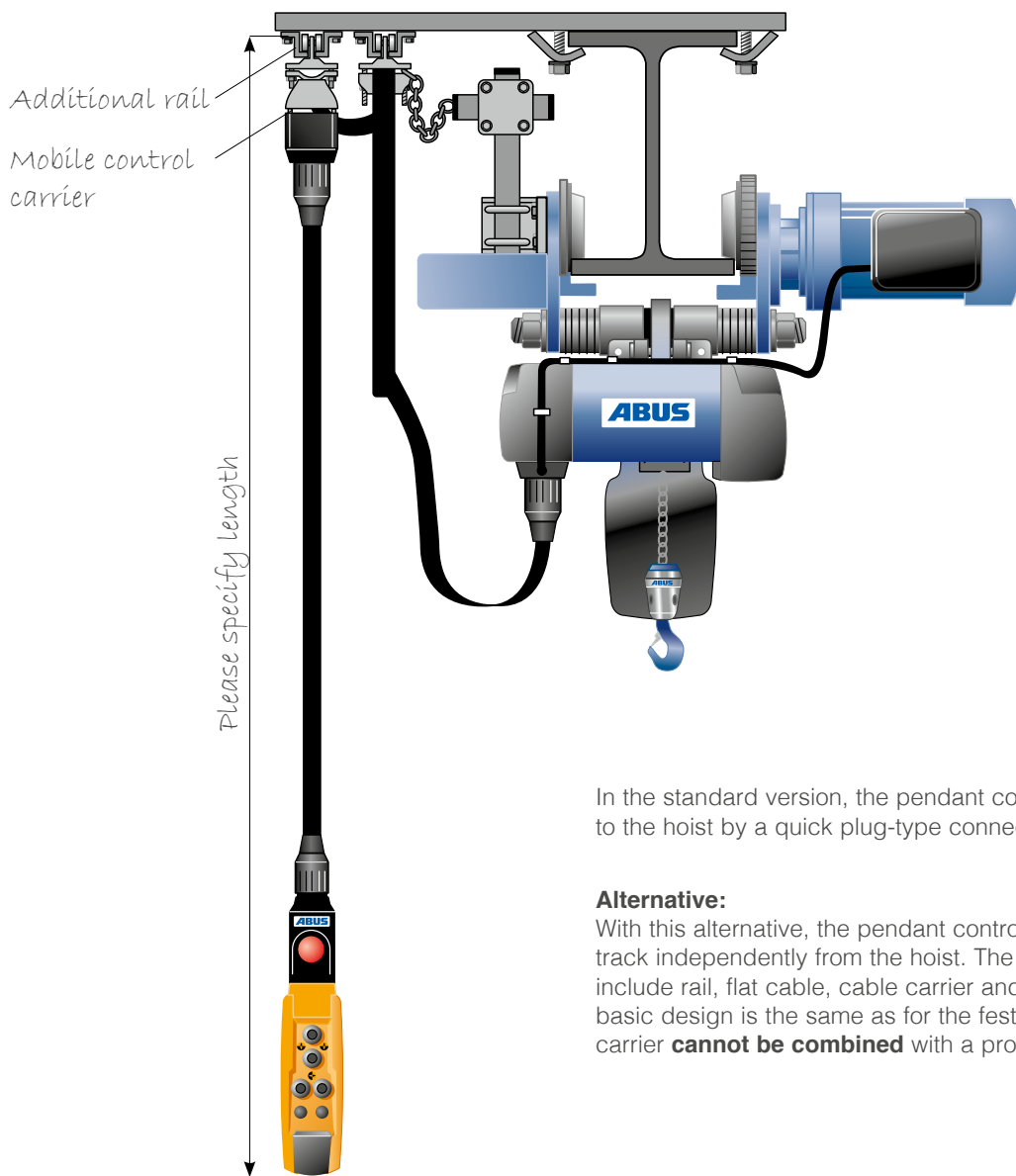

In the standard version, the pendant control is attached directly to the hoist by a quick plug-type connector.

### Alternative:

With this alternative, the pendant control can be moved along the trolley track independently from the hoist. The additional components required include rail, flat cable, cable carrier and control carrier with connector. The basic design is the same as for the festoon cable system. A mobile control carrier **cannot be combined** with a protected conductor system.

Fixed components	Length-dependent components	The voltage drop must be taken into consideration for the design of the system.
Fixed components as for festoon system on page 19, plus: end clamp, mobile control carrier, bolted joints, end stop	Length-dependent components as for festoon system on page 19, plus: additional cable carriers, flat cable, rail supports, rail connectors for mobile control carrier	The system is prefabricated, i.e. supplied with the flat cable on the cable carriers, current collector carrier and end clamp.

# ABUS safety conductor system

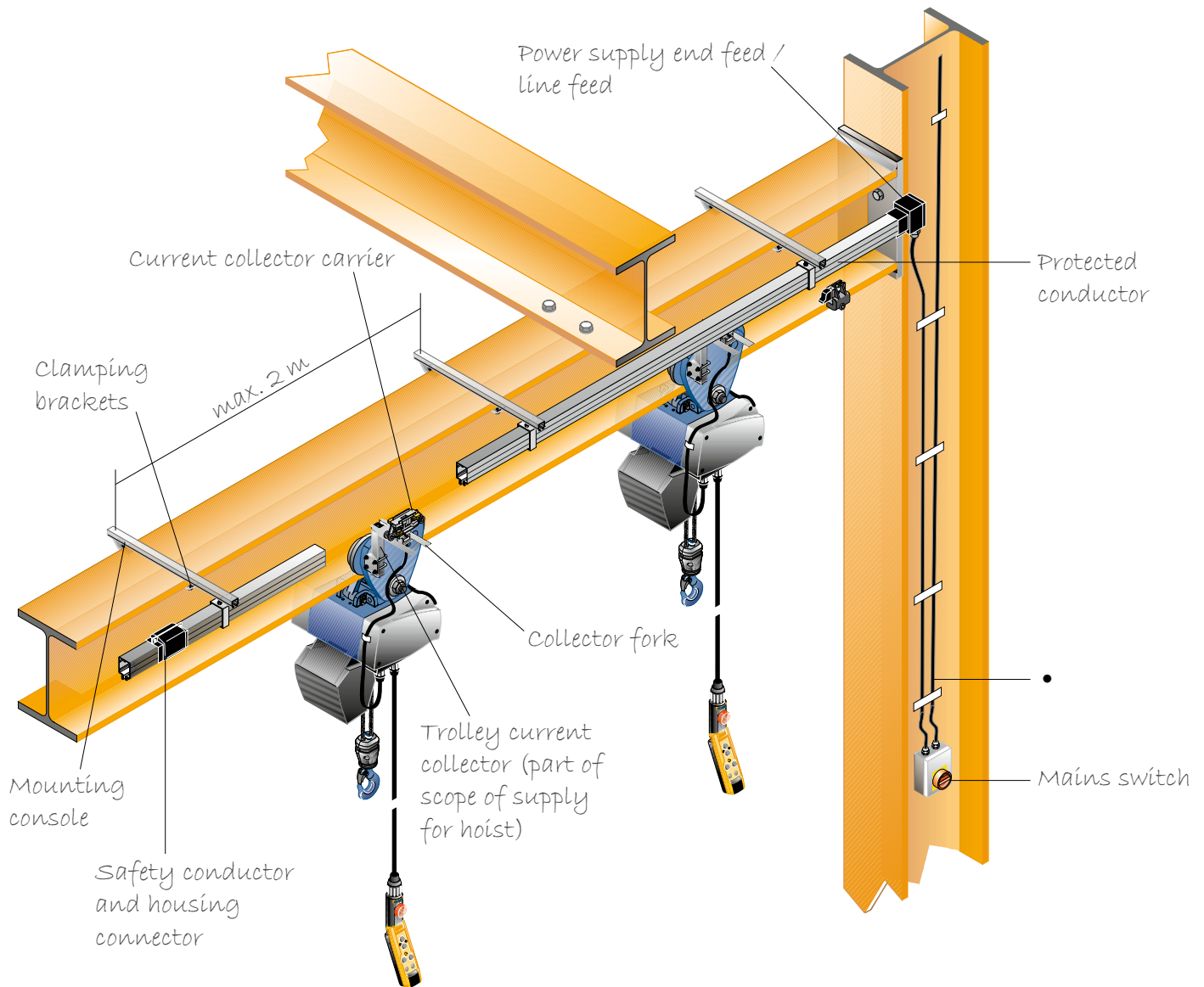

Fixed components	Length-dependent components
End cap(s), end/line feed, Fixed point suspension, Collector with 2 m connection cable, collector fork and mains switch	Safety conductor, sliding mounts, mounting consoles, clamping brackets
Type	Type
KBH 4/63-HS	KBH 4/63-HS
KBH 5/63-HS	KBH 5/63-HS

Power supply from the centre of the conductor is required if the track length is above 30 m.

- The riser cable from the mains switch and cabling to the power supply point, including accessories, are not included in the scope of supply.

The voltage drop corresponding to the track length must be taken into consideration for the design of the safety conductor system.

# Weights and dimensions

## ABUCompact

Dimensions, ABUCompact GM2 to GM8

Model	Width			Length				Height		Suspension bracket			
	B mm	B3 mm	B4 mm	L mm	L1 mm	L2 mm	L3 mm	H mm	H1 mm	D1 mm	H2 mm	T mm	B5 mm
GM2	346	175	171	297	165	132	103	198	129	40	69	21	24
GM4	402	217	185	353	197	156	120	237	158	40	79	21	24
GM6	472	281	191	436	225	211	160	303	196	63	107	28	28
GM8	542	306	236	472	254	218	198	342	235	63	107	28	28
GM8 <sup>1)</sup>	542	306	236	472	254	218	198	372	235	73	137	33	28

(fold-out dimensioned sketches on pages 3 and 30)

Dimensions, ABUCompact GM2 to GM8 with additional housing

Model	Width			Length				Height		Suspension bracket			
	B mm	B3 mm	B4 mm	L mm	L1 mm	L2 mm	L3 mm	H mm	H1 mm	D1 mm	H2 mm	T mm	B5 mm
GM2	346	175	171	352	220	132	103	198	129	40	69	21	24
GM4	402	217	185	390	234	156	120	237	158	40	79	21	24
GM6	472	281	191	517	306	211	160	303	196	63	107	28	28
GM8	542	306	236	567	349	218	198	342	235	63	107	28	28
GM8 <sup>1)</sup>	542	306	236	567	349	218	198	372	235	73	137	33	28

<sup>1)</sup> with EF 50 for load capacity 4000 kg

Dimensions, ABUCompact GM2 to GM8, stationary and with trolley

Model	Load falls	Hook	Trolley	C mm	C1 mm	C3 mm	D1 mm	D2 mm	A3 mm
GM2	1	012	HF 3	348	394	46	40	30	19
GM2	1	012	HF 6	348	400	52,5	40	30	19
GM2	1	012	HF 14	348	416	68	40	30	19
GM2	1	012	EF 14	348	416	68	40	30	19
GM2	1	025	HF 6	362	414	52,5	40	36	25
GM2	1	025	HF 14	362	430	68	40	36	25
GM2	1	025	EF 14	362	430	68	40	36	25
GM2	2	05	HF 3	424	470	46	40	43	31
GM2	2	05	HF 6	424	476	52,5	40	43	31
GM2	2	05	HF 14	424	492	68	40	43	31
GM2	2	05	EF 14	424	492	68	40	43	31
GM4	1	025	HF 3	400	446	46	40	36	25
GM4	1	025	HF 6	400	452	52,5	40	36	25
GM4	1	025	HF 14	400	468	68	40	36	25
GM4	1	025	EF 14	400	468	68	40	36	25
GM4	2	05	HF 6	476	528	52,5	40	43	31
GM4	2	05	HF 14	476	544	68	40	43	31
GM4	2	05	EF 14	476	544	68	40	43	31
GM6	1	05	HF 14	494	562	68	63	43	31
GM6	1	05	EF 14	494	592	68	63	43	31
GM6	2	1	HF 22	566	645	79	63	50	34
GM6	2	1	EF 22	566	645	79	63	50	34
GM6	2	1	HF 36	566	650	84	63	50	34
GM6	2	1	EF 36	566	650	84	63	50	34
GM8	1	05	HF 22	565	644	79	63	43	31
GM8	1	05	EF 22	565	644	79	63	43	31
GM8	2	1	HF 22	695	774	79	63	50	34
GM8	2	1	EF 22	695	774	79	63	50	34
GM8	2	1	HF 36	695	779	84	63	50	34
GM8	2	1	EF 36	695	779	84	63	50	34
GM8	2	1	HF 50	725	810	85	73	50	34
GM8	2	1	EF 50	725	810	85	73	50	34

Weights and dimensions dependant on hook path, ABUCompact GM2 to GM8

Model	Load falls	Hook path	D1 mm	H2 mm	C2 mm	Weight kg
GM2	1	3000	40	69	365	21,8
GM2	1	4000	40	69	365	22,2
GM2	1	5000	40	69	402	22,5
GM2	1	6000	40	69	402	22,8
GM2	1	8000	40	69	402	23,5
GM2	1	10000	40	69	402	24,2
GM2	1	12000	40	69	498	24,9
GM2	1	16000	40	69	498	26,2
GM2	1	20000	40	69	498	27,6
GM2	1	24000	40	69	498	29,0
GM2	1	32000	40	69	614	31,7
GM2	2	3000	40	69	402	24,4
GM2	2	4000	40	69	402	25,1
GM2	2	5000	40	69	402	25,8
GM2	2	6000	40	69	498	26,5
GM2	2	8000	40	69	498	27,8
GM2	2	10000	40	69	498	29,2
GM2	2	12000	40	69	498	30,6
GM2	2	16000	40	69	614	33,3
GM4	1	3000	40	79	427	34,5
GM4	1	4000	40	79	427	35,2
GM4	1	5000	40	79	527	35,8
GM4	1	6000	40	79	527	36,5
GM4	1	8000	40	79	527	37,8
GM4	1	10000	40	79	527	39,1
GM4	1	12000	40	79	639	40,4
GM4	1	16000	40	79	639	43,0
GM4	1	20000	40	79	639	45,6
GM4	1	24000	40	79	639	48,2
GM4	1	32000	40	79	800	53,4
GM4	1	50000	40	79	800	65,1
GM4	2	3000	40	79	527	38,0
GM4	2	4000	40	79	527	39,3
GM4	2	5000	40	79	527	40,6
GM4	2	6000	40	79	639	41,9
GM4	2	8000	40	79	639	44,5
GM4	2	10000	40	79	639	47,1
GM4	2	12000	40	79	639	49,7
GM4	2	16000	40	79	800	54,9
GM4	2	20000	40	79	800	60,1
GM4	2	25000	40	79	800	66,6
GM6	1	3000	63	107	551	57,6
GM6	1	4000	63	107	551	58,9
GM6	1	5000	63	107	551	60,1
GM6	1	6000	63	107	551	61,4
GM6	1	8000	63	107	551	63,8
GM6	1	10000	63	107	711	66,3
GM6	1	12000	63	107	711	68,8
GM6	1	16000	63	107	711	73,8
GM6	1	20000	63	107	711	78,7
GM6	1	24000	63	107	873	83,7
GM6	1	32000	63	107	873	93,6
GM6	1	35000	63	107	873	97,3
GM6	2	3000	63	107	551	62,6
GM6	2	4000	63	107	551	65,1
GM6	2	5000	63	107	711	67,6
GM6	2	6000	63	107	711	70,1
GM6	2	8000	63	107	711	75,0
GM6	2	10000	63	107	711	80,0
GM6	2	12000	63	107	873	85,0
GM6	2	16000	63	107	873	94,9
GM6	2	17500	63	107	873	98,6

(fold-out dimensioned sketches on pages 3 and 30)

Weights and dimensions dependant on hook path, ABUCompact GM2 to GM8

Model	Load falls	Hook path	D1 mm	H2 mm	C2 mm	Weight kg
GM8	1	3000	63	107	818	92,3
GM8 <sup>1)</sup>	1	3000	73	137	848	92,3
GM8	1	4000	63	107	818	94,5
GM8 <sup>1)</sup>	1	4000	73	137	848	94,5
GM8	1	5000	63	107	818	96,8
GM8 <sup>1)</sup>	1	5000	73	137	848	96,8
GM8	1	6000	63	107	818	99,1
GM8 <sup>1)</sup>	1	6000	73	137	848	99,1
GM8	1	8000	63	107	818	103,6
GM8 <sup>1)</sup>	1	8000	73	137	848	103,6
GM8	1	10000	63	107	818	108,2
GM8 <sup>1)</sup>	1	10000	73	137	848	108,2
GM8	1	12000	63	107	818	112,7
GM8 <sup>1)</sup>	1	12000	73	137	848	112,7
GM8	1	16000	63	107	818	121,8
GM8 <sup>1)</sup>	1	16000	73	137	848	121,8
GM8	1	20000	63	107	968	130,9
GM8 <sup>1)</sup>	1	20000	73	137	998	130,9
GM8	1	32000	63	107	1168	158,1
GM8 <sup>1)</sup>	1	32000	73	137	1198	158,1
GM8	2	3000	63	107	818	101,1
GM8 <sup>1)</sup>	2	3000	73	137	848	101,1
GM8	2	4000	63	107	818	105,6
GM8 <sup>1)</sup>	2	4000	73	137	848	105,6
GM8	2	5000	63	107	818	110,2
GM8 <sup>1)</sup>	2	5000	73	137	848	110,2
GM8	2	6000	63	107	818	114,7
GM8 <sup>1)</sup>	2	6000	73	137	848	114,7
GM8	2	8000	63	107	818	123,8
GM8 <sup>1)</sup>	2	8000	73	137	848	123,8
GM8	2	10000	63	107	968	132,9
GM8 <sup>1)</sup>	2	10000	73	137	998	132,9
GM8	2	16000	63	107	1168	160,1
GM8 <sup>1)</sup>	2	16000	73	137	1198	160,1

Dimensions, ABUCompact GMC

<sup>1)</sup>with EF 50 for load capacity 4000 kg

Model	Width			Length				Height		Suspension bracket			
	B mm	B3 mm	B4 mm	L mm	L1 mm	L2 mm	L3 mm	H mm	H1 mm	D1 mm	H2 mm	T mm	B5 mm
GMC	275	115	160	290	175	115	0	196	130	22	66	9	18

Dimensions, ABUCompact GMC, stationary and with trolley

Model	Load falls	Hook	Trolley	C mm	C1 mm	C3 mm	D1 mm	D2 mm	A3 mm
GMC	1	012	HF 3	329	375	46	36	30	19
GMC	2	025	HF 3	374	420	46	36	36	25

Weights and dimensions dependant on hook path, ABUCompact GMC

Model	Load falls	Hook path	D1 mm	C2 mm	Weight kg
GMC	1	3000	22	359	10,1
GMC	1	6000	22	359	10,7
GMC	1	10000	22	359	11,5
GMC	1	20000	22	394	13,6
GMC	2	3000	22	359	11,2
GMC	2	6000	22	359	12,5
GMC	2	10000	22	394	14,1



# Weights and dimensions

## ABUS HF push trolleys

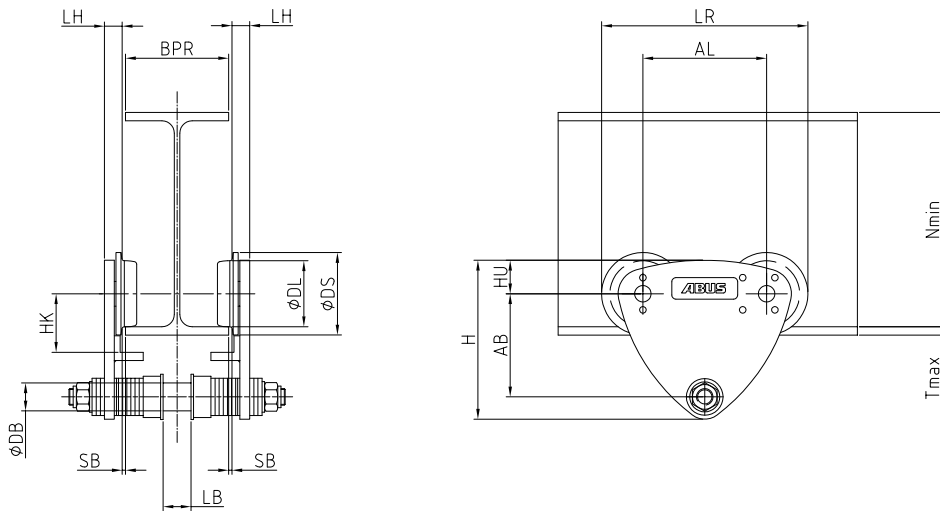

Dimension table, ABUS HF push trolleys

Model	Flange width BPR mm	Load capacity kg	Dimensions mm													Ref.	Weight kg	Model	Flange width BPR mm	Minimum bend radius mm	
			AL	AB	DL	DS	DB	H	HK	HU	LB	LR	LH	SB (max.)	Nmin						Tmax
HF 3	42-120	300	90	85	56	75	22	135	47	29	31	165	17	2	110	20	110243	3,9	HF 3	42 - 70	600
HF 3	121-180	300	90	85	56	75	22	135	47	29	31	165	17	2	110	20	110244	4,4		71 - 85	700
HF 6	42-120	580	120	100	65	85	30	153	55	32	32	205	19	2	120	20	110245	6,1		86 - 120	1000
HF 6	121-220	580	120	100	65	85	30	153	55	32	32	205	19	2	120	20	110246	6,7		121 - 180	1200
HF 14	64-125	1400	150	125	80	100	34	193	71	41	33	250	22	2	130	25	74097	11	HF 6	42 - 70	700
HF 14	126-200	1400	150	125	80	100	34	193	71	41	33	250	22	2	130	25	74098	11,7		71 - 85	800
HF 14	201-300	1400	150	125	80	100	34	193	71	41	33	250	22	2	130	25	74099	12,6		86 - 120	1100
HF 14	301-400	1150	150	125	80	100	34	193	71	41	33	250	22	2	130	25	123652	13,3		121 - 180	1300
HF 22	82-150	2200	180	160	112	140	50	236	90	41	42	320	28	2	160	28	110250	23,2	HF 14	181 - 220	1600
HF 22	151-200	2200	180	160	112	140	50	236	90	41	42	320	28	2	160	28	110251	23,9		64 - 90	1100
HF 22	201-300	2200	180	160	112	140	50	236	90	41	42	320	28	2	160	28	110252	25,8		91 - 125	1500
HF 22	301-400	1800	180	160	112	140	50	236	90	41	42	320	28	2	160	28	123653	27,3		126 - 140	1700
HF 36	90-155	3600	180	170	112	140	60	253	90	41	50	320	33	2	160	28	110253	29,7	HF 22	141 - 200	2100
HF 36	156-200	3600	180	170	112	140	60	253	90	41	50	320	33	2	160	28	110254	30,4		201 - 300	2300
HF 36	201-300	3600	180	170	112	140	60	253	90	41	50	320	33	2	160	28	110255	32,2		301 - 400	2500
HF 36	301-400	2900	180	170	112	140	60	253	90	41	50	320	33	2	160	28	123654	34,4		90 - 125	1700
HF 50	100-195	5000	220	190	140	180	70	348	115	90	46	400	54	2	190	40	110529	65,5	HF 36	126 - 140	2100
HF 50	200-305	5000	220	190	140	180	70	348	115	90	44	400	54	2	190	40	110530	70,5		141 - 200	2200
																			HF 50	201 - 300	2300
																				90 - 125	1800
																			126 - 200	2000	
																			201 - 300	2200	

# Weights and dimensions

## ABUS EF electric trolleys

ABUS EF 14 – 36 electric trolleys

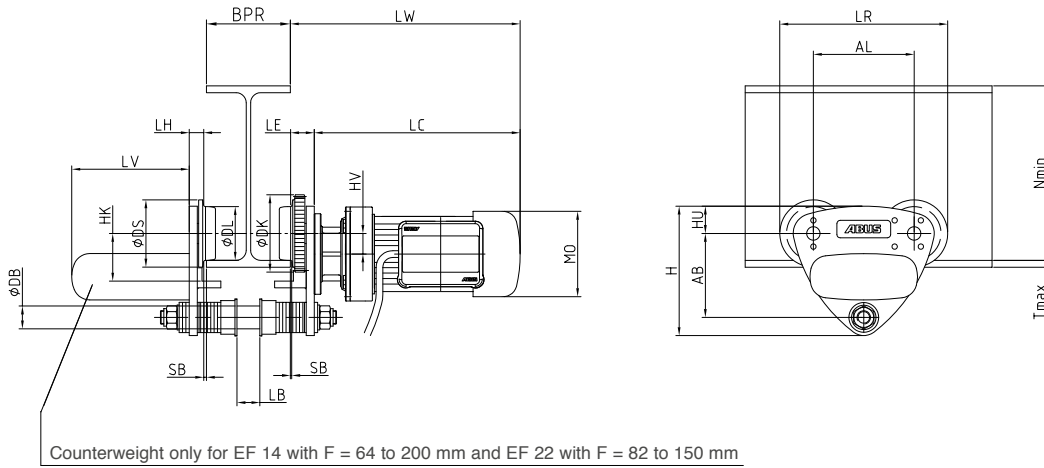

Dimension table, ABUS EF electric trolleys

Model	Flanges width BPR	Load capacity	Travel speed	Rating	Duty cycle	Dimensions											
						mm											
						AL	AB	DL	DS	DK	DB	H	HK	HV	HU	LB	LR
EF 14	64-125	1400	5/20	0.06/0.25	50	150	125	80	100	115	34	193	71	31,5	41	33	265
EF 14	126-200	1400	5/20	0.06/0.25	50	150	125	80	100	115	34	193	71	31,5	41	33	265
EF 14	201-300	1400	5/20	0.06/0.25	50	150	125	80	100	115	34	193	71	31,5	41	33	265
EF 14	301-400	1150	5/20	0.06/0.25	50	150	125	80	100	115	34	193	71	31,5	41	33	265
EF 22	82-150	2200	5/20	0.06/0.25	50	180	160	112	140	155	50	236	90	47	41	42	335
EF 22	151-200	2200	5/20	0.06/0.25	50	180	160	112	140	155	50	236	90	47	41	42	335
EF 22	201-300	2200	5/20	0.06/0.25	50	180	160	112	140	155	50	236	90	47	41	42	335
EF 22	301-400	1800	5/20	0.06/0.25	50	180	160	112	140	155	50	236	90	47	41	42	335
EF 36	90-155	3600	5/20	0.06/0.25	50	180	170	112	140	155	60	253	90	47	41	50	335
EF 36	156-200	3600	5/20	0.06/0.25	50	180	170	112	140	155	60	253	90	47	41	50	335
EF 36	201-300	3600	5/20	0.06/0.25	50	180	170	112	140	155	60	253	90	47	41	50	335
EF 36	301-400	2900	5/20	0.06/0.25	50	180	170	112	140	155	60	253	90	47	41	50	335
EF 50	100-195	5000	5/20	0.09/0.37	50	220	190	140	180	183	70	348	115	30	90	46	403
EF 50	200-305	5000	5/20	0.09/0.37	50	220	190	140	180	183	70	348	115	30	90	44	403

ABUS EF 50 electric trolleys

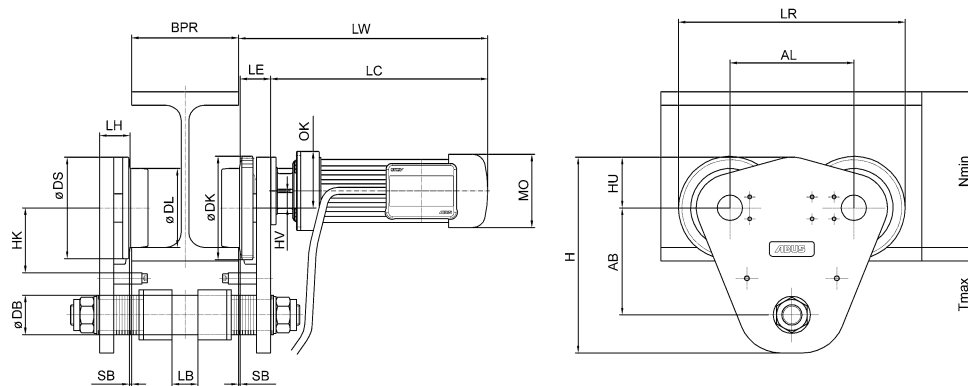

Dimensions											Ref.	Weight
mm												
LH	LV	SB (max.)	LE	LW	LC	MO	OK	Nmin	Tmax			
22	175	2	34	389	355	140	-	165	25	124551	37,1	
22	175	2	34	389	355	140	-	165	25	124552	37,8	
22	0	2	34	389	355	140	-	165	25	124553	27,1	
22	0	2	34	389	355	140	-	165	25	124554	27,8	
28	175	2	39	394	355	140	-	200	28	124555	49,4	
28	0	2	39	394	355	140	-	200	28	124556	38,6	
28	0	2	39	394	355	140	-	200	28	124557	40,5	
28	0	2	39	394	355	140	-	200	28	124558	42	
33	0	2	44	393	349	140	-	200	28	124559	43,9	
33	0	2	44	393	349	140	-	200	28	124560	44,2	
33	0	2	44	393	349	140	-	200	28	124561	46,5	
33	0	2	44	393	349	140	-	200	28	124562	48,7	
54	0	2	54	465	411	157	110	230	40	124563	87,9	
54	0	2	54	465	411	157	110	230	40	124564	92,9	

Model	Flange width BPR	Minimum bend radius
	mm	mm
EF 14	64 - 90	1100
	91 - 125	1500
	126 - 140	1700
	141 - 200	2100
	201 - 300	2250
EF 22	301 - 400	2400
	82 - 125	1700
	126 - 140	2100
	141 - 200	2200
EF 36	201 - 300	2300
	301 - 400	2500
	90 - 125	1700
	126 - 140	2100
EF 50	141 - 200	2200
	201 - 300	2300
	301 - 400	2500
	90 - 125	1800
	126 - 200	2000
	201 - 300	2200

# Suspension hooks / safety hooks

for use with ABUS electric chain hoists

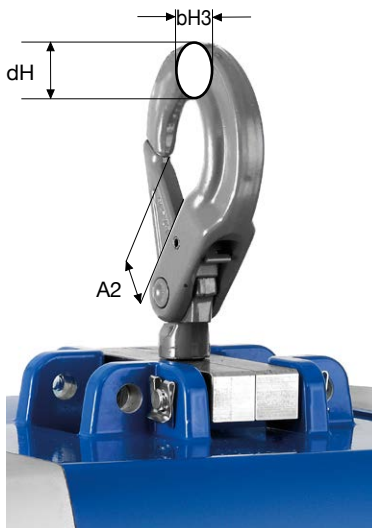

Suspension hooks



Safety hook

## Overview of how to use the suspension hooks

Model of chain hoist	Maximum load capacity kg	Standard	Suspension hooks		
			Type	Ref.	Larger C dimensions mm
GMC	200	suspension bracket	BKT 6-10	313237	64
GM2	630	suspension bracket	BKT 7/8-10	313238	80
GM4	1250	suspension bracket	BKT 7/8-10	313238	70
GM6	2500	suspension bracket	BKT 13-10	313239	125

## Use with ABUS travel trolleys

Model of chain hoist	Ref.	Possible trolley combinations
GMC	313237	HF 3
GM2	313238	HF 3 to Tmax = 10 mm, HF 6, EF 14
GM4	313238	HF 3 to Tmax = 10 mm, HF 6, HF/EF 14
GM6	313239	HF/EF 14 to Tmax = 15 mm, HF/EF 22

## How safety hooks can be used with ABUS electric chain hoists

Model of chain hoist / No. of falls	Maximum load capacity kg	Standard  Hook Type	Safety hook			
			Type	Ref.	Larger C dimensions mm	Iges mm
GMC / single fall	100	012	BKT 7/8-10	76056	44	193
GMC / double falls	200	025	BKT 7/8-10	71859	30	193
GM2 / single fall	250	012	BKT 7/8-10	76056	44	193
GM2 / single fall	320	025	BKT 7/8-10	76056	29	193
GM2 / double falls	630	05	BKT 7/8-10	71860	4	227
GM4 / single fall	630	025	BKT 7/8-10	76056	29	193
GM4 / double falls	1250	05	BKT 7/8-10	71860	4	243
GM6 / single fall	1250	05	BKT 13-10	76057	75	278
GM8 / single fall	2000	05	BKT 13-10	76057	75	298

## Dimensions

Type	Dimensions in mm						
	A2	bH1	bH2	bH3	bH4	d2	dH
BKT 6-10	28	32	42	16	23	36	21
BKT 7/8-10	37	38	48	20	28	45	25
BKT 13-10	54	59	78	32	37	69	39

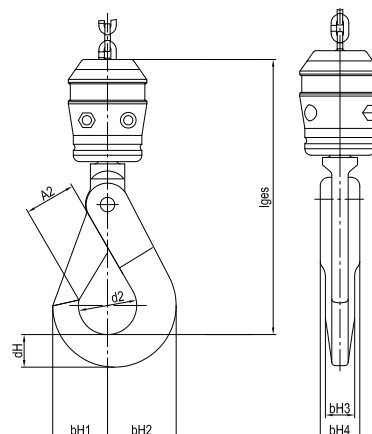

Safety hook

# Anti-collision protection

for ABUS trolleys EF/HF

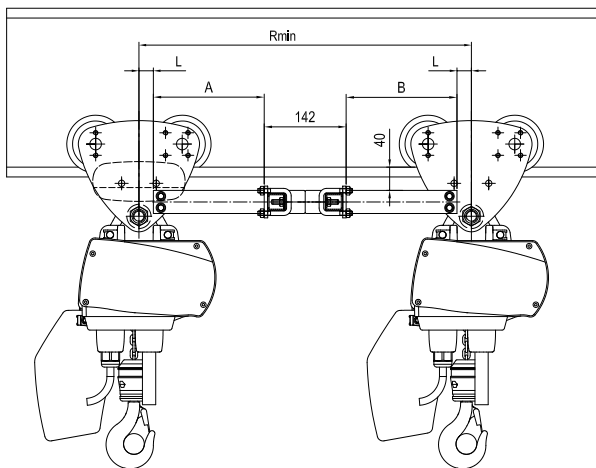

Trolley type	Chain hoist combination	Distance (mm)			
		A	B	L	R min
HF 3	GMC / GMC	192	192	44,5	615
	GMC / GM2				
	GMC / GM4				
	GM2 / GM2				
	GM2 / GM4				
GM4 / GM4					
HF 6	GM2 / GM2	192	192	54	634
	GM2 / GM4				
HF / EF 14	GM2 / GM2	192	192	25	576
	GM2 / GM4				
	GM2 / GM6				
	GM4 / GM4				576
HF / EF 22	GM4 / GM4	192	192	58	668
	GM4 / GM6	192	284		760
	GM6 / GM6	284	284		734
HF / EF 36	GM6 / GM6	192	284	71	734
	GM6 / GM8	192	284		826
	GM8 / GM8	284	284		668
HF / EF 50	GM8 / GM8	192	284	92	802

## Application

Mechanical collision protection between two adjacent ABUS trolleys on a trolley support.

Flange width	Article number
42 - 305 mm	123209
306 - 400 mm	123210

Anti-collision protection is required for each trolley and direction of travel.

# Dimensioned sketches of chain hoists

## ABUCompact GM6 and GM8

stationary

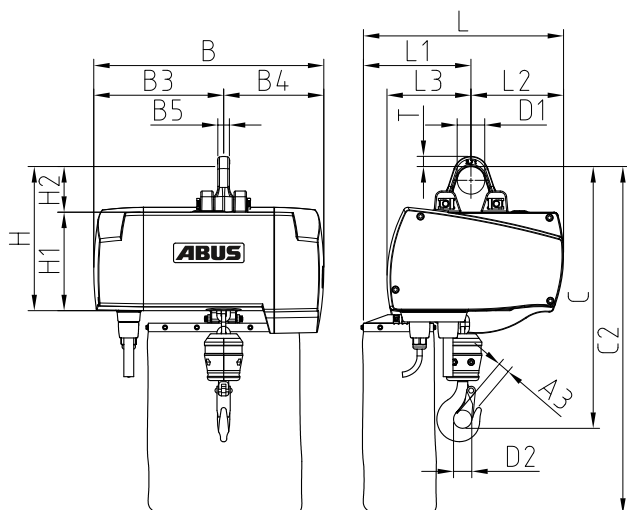

with additional housing  
and brake resistor for frequency converter

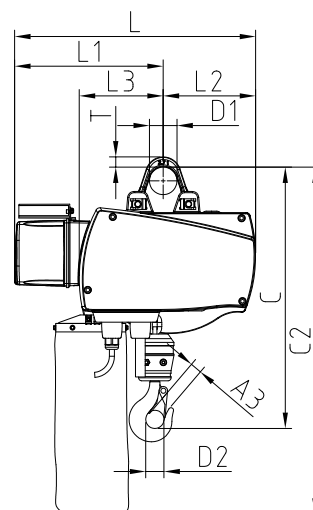

with HF push trolley

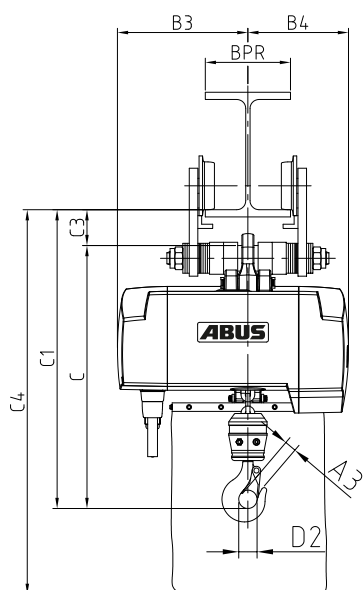

with EF electric trolley

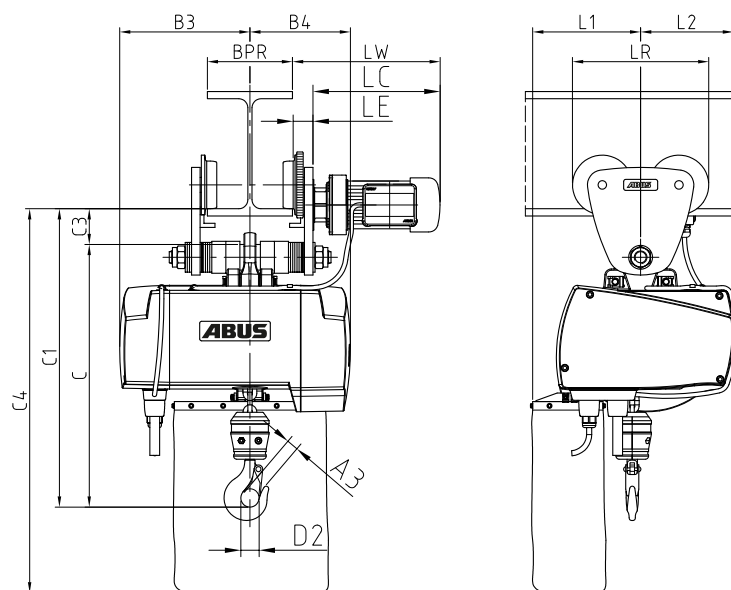

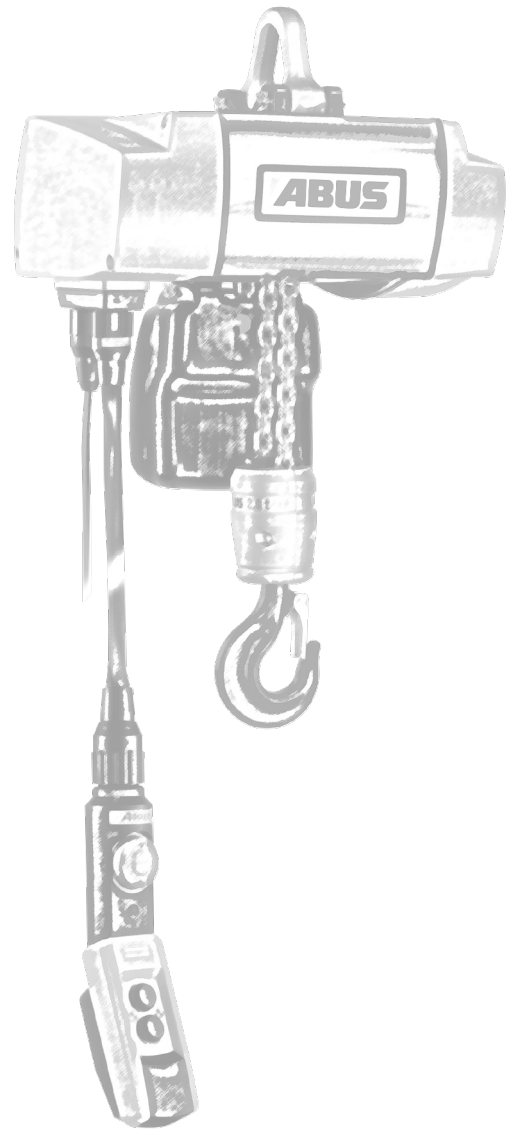
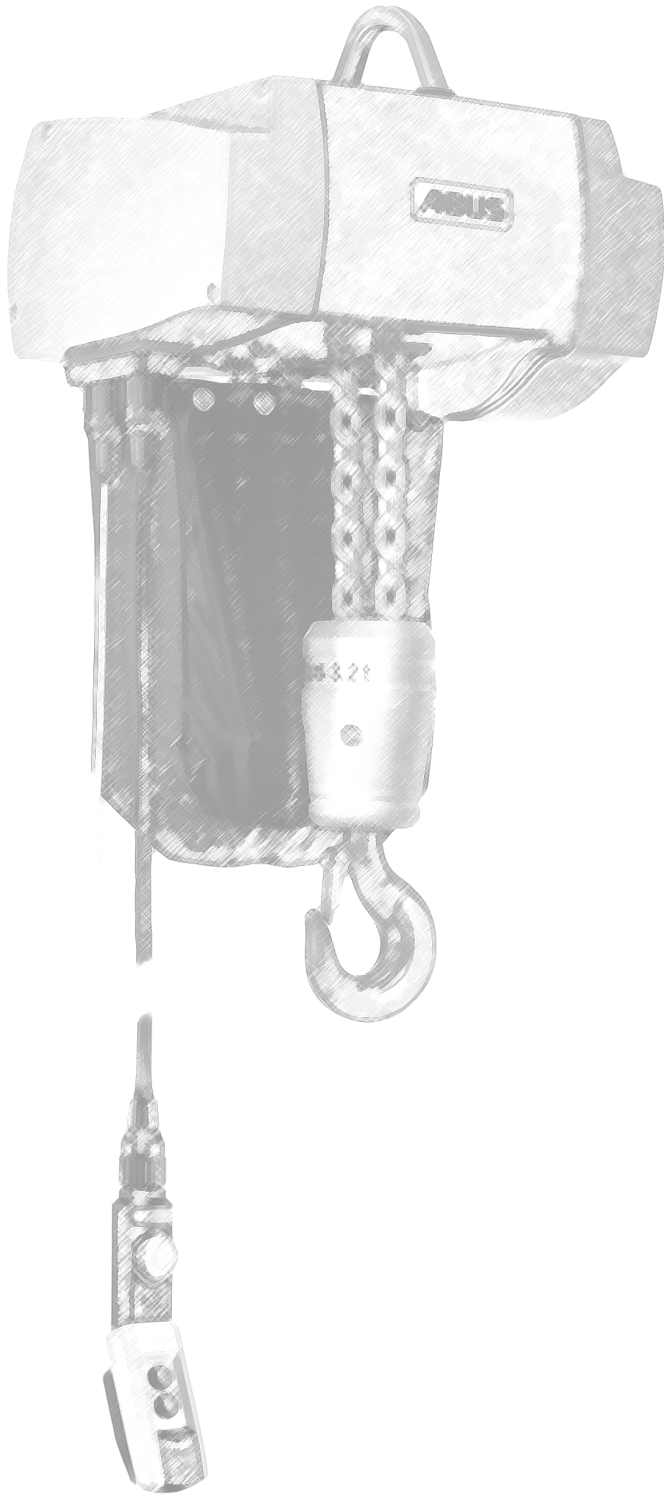

Please use the enquiry forms at [www.morris.co.za](http://www.morris.co.za)

Dimensioned sketches  
ABUCompact GM6 and GM8

Please fold page out



# Further product information...

...on ABUS lightweight crane systems and on our entire product range will be gladly forwarded to you. You can also view these directly and download them from our homepage.



ABUS Image brochure



The Product Overview



Jib cranes



HB-System



HB support structures



Mobile gantries

**Please send your request**  
by fax to: +27 (0)11 7481093

by email to: [sales@morris.co.za](mailto:sales@morris.co.za)

Name: \_\_\_\_\_

Company: \_\_\_\_\_

Street: \_\_\_\_\_

Postal code/City/Country: \_\_\_\_\_

Telephone: \_\_\_\_\_

E-mail: \_\_\_\_\_

Date \_\_\_\_\_ Signature \_\_\_\_\_

714726/200/06.17